

# V-TAC

Meaningful Innovation.

WEEE Number: 80133970

## INSTRUCTION MANUAL



LITHIUM ION BATTERIES

MODEL	SKU
VT-14033	12713
VT-14033	12714



**10** YEAR  
**WARRANTY\***

( as per conditions met)

## INTRODUCTION

Thank you for selecting and buying V-TAC Product. V-TAC will serve you the best. Please read these instructions carefully & keep this user manual handy for future reference. If you have any another query, please contact our dealer or local vendor from whom you have purchased the product. They are trained and ready to serve you at the best.



### MULTI-LANGUAGE MANUAL QR CODE

Please scan the QR code to access the manual in multiple languages.



Points de collecte sur [www.quefairedemesdechets.fr](http://www.quefairedemesdechets.fr)

## ATTENTION!

Due to the extended transportation period, anomalies in the calculation of the battery's SOC (State of Charge) and capacity may occur.

Please follow the steps below during the initial commissioning of the battery:

- Discharge the battery until the low battery alarm is triggered.
- Fully charge the battery to its maximum capacity.

Performing these two steps will help recalibrate the SOC and ensure accurate capacity measurements.

### IMPORTANT NOTES

- This product contains battery type "Secondary" (rechargeable).
- Electrical and electronic equipment that has become waste is known as old equipment/device. Old devices must not be disposed of with other household waste.
- Owners of old devices at the end of its service life must return the device by taking them to the collection points set up by public waste disposal authorities or distributors. This return does not entail any costs for you.
- Owners of old devices have an obligation to remove accessible batteries / rechargeable batteries as well as non-destructively removable lamps from the old device prior to return. This does not apply if old devices are being prepared for reuse with the participation of a public law firm.
- Battery removal warning: The battery contained in this product must be removed only by professional personnel only. The battery must never be removed by the end user, if not removed correctly it could damage the battery which could cause fire.
- Batteries removed from an old electronic device should be disposed of separately. This return of battery does not entail any costs for you and the user is obliged to return the battery.
- Please make sure that this product is not powered on when removing the battery. Fire hazard! Avoid short-circuiting the contacts of a detached battery. Do not incinerate the battery. Please handle the battery with Caution!
- If electrical appliances or batteries are disposed of in landfills or dumps, hazardous substances can leak into the groundwater and get into the food chain, damaging your health and well-being.



- The symbol of "Crossed rubbish bins" indicates that this product should not be disposed of with other household wastes and must be collected separately from unsorted municipal waste at the end of its service life.
- Please use the link below to view the online directory of the collection and return points: <https://www.ear-system.de/ear-verzeichnis/sammel-und-ruecknahmestellen>

# Contents

1 Foreword.....	1
2 Safety.....	2
2.1 Safety Precautions.....	3
2.2 Abuse Operation.....	3
3 Overview.....	4
3.1 Product Description.....	4
3.1.1 Features.....	4
3.1.2 Basic Functions.....	4
3.2 Application Scenario.....	5
4 Application Description.....	6
4.1 Parallel Connection Application.....	6
4.2 Low-temperature Application.....	6
4.3 Low Battery-capacity Storage (SOC≤5%).....	6
4.4 Application of Nearing the Ocean.....	7
5 Product Introduction.....	8
5.1 Dimensions.....	8
5.2 Panel Introduction.....	9
5.3 Definition of indicator light illumination sequence .....	12
6 Installation.....	15
6.1 Precautions for Installation.....	15
6.2 Installation Preparation.....	15
6.2.1 Tools Preparation.....	17
6.3 Packing List.....	17
6.4 Unpacking and Inspection.....	18
6.5 Installation.....	19
6.6 Cable Connection.....	20
6.6.1 Power Cable Connection.....	20
6.6.2 Communication Cable Connection.....	21
6.6.3 Grounding Cable Connection.....	22
7 Parallel Connection.....	23
8 Make Your System Run.....	28
9 Shipment & Maintenance & Storage.....	30
9.1 Shipment.....	30
9.2 Maintenance.....	30
9.2.1 Battery Maintenance Considerations.....	30
9.2.2 Routine Maintenance.....	31
9.3 Battery Storage.....	32
10 Trouble Shooting.....	33
11 Warranty.....	34
12 Abbreviations.....	35
13 Screen instructions.....	36
14 Wireless module ( APP).....	44

## ► Overview

This user manual mainly introduces product introduction, application description, installation instructions, power-on instructions, maintenance instructions and provides instructions the VT-14033 Series LFP battery pack for technical support engineers, maintenance engineers and users.





## ► Reader

This document is mainly applicable to the following engineers

- Technical Support Engineer
- Installation Personnel
- Maintenance Engineer













## ► Signs

The following signs may appear in this article, and their meanings are as follows.

Sign	Meaning	Description
	Danger	Indicates a hazard with a high level of risk that will cause death or serious injury if not avoided.
	Warning	Indicates a hazard with a moderate risk that may cause death or serious injury if not avoided.
	Notice	Indicates a hazard with a low level of risk that may cause minor or moderate harm if not avoided.
	Explanation	Supplementary explanation of key information in the main text. "Explanation" is not safety warning information, and does not involve personal, equipment and environmental damage information.
	Warning	This device has an IP20 protection rating, which means it is designed for indoor use only. Do not expose this device to moisture or outdoor conditions, as it may cause damage or pose safety risks.

## 2 Safety

### Symbol Description

	<p>Potential risks exist. Wear proper personnel protectives before any operations.</p>		<p>Refer to instruction manual/booklet</p>
	<p>HIGH VOLTAGE HAZARD. High voltage exists during the equipment's running. Ensure the equipment is power off before any operations.</p>		<p>No extinguishing with water.</p>
	<p>Batteries contain flammable materials. Beware of fire.</p>		<p>Put the battery in the right place and recycle it in compliance with local environmental regulations.</p>
	<p>Install the equipment away from fire sources.</p>		<p>Product compliant with the requirements of European Union directives.</p>
	<p>This marking indicates that this product should not be disposed of with other household wastes.</p>		<p>Designation of the packaging material – corrugated cardboard</p>
	<p>Symbol indicating that the manufacturer has contributed financially to the construction and operation of packaging material recovery and recycling system.</p>		<p>"hot aerosol fire extinguishing device" extinguishant</p>

### ▶ 2.1 Safety Precautions

Before carrying out battery work, you must read carefully the safety precautions and master the correct installation and connection methods of the battery.

- Prohibit to turn it upside down, tilt, or collide.
- Prohibit to short-circuit the positive and negative poles of the battery, otherwise it will cause the battery to be damaged.
  - Prohibit to throw the battery pack into a fire source.
  - Prohibit to modify the battery, and it is strictly prohibited to immerse the battery in water or other liquids.
    - DO NOT place installation tools on the battery during battery installation.
    - DO NOT disassemble, squeeze, bend, deform, puncture, or shred the battery without the authorization of authorized dealers.
      - DO NOT exceed the temperature range, otherwise it will affect the battery performance and safety.
        - The battery circuit must be kept disconnecting status during installation and maintenance operations.
        - Check the battery connection end bolts regularly to confirm that the bolts are tight.

### ▶ 2.2 Abuse Operation

The battery pack needs to avoid abuse operations under the following (including but not limited to) conditions:

Abuse Operation	Protection Description
Reverse connection of positive and negative poles	If the positive and negative poles are connected reversely, the battery will be directly damaged.
External short circuit	If the battery pack is short circuited externally, the battery will be directly damaged.
Series connection application	The battery pack does not support the application of battery packs in series. If the battery packs are forced to be connected in series, the batteries may be directly damaged, and may even cause fire, explosion and other dangers.

## 3 Overview

### ▶ 3.1 Product Description

The VT-16076W, VT-16076B product use lithium iron phosphate (LFP) as the positive electrode material. It can be widely used in energy storage systems such as residential energy storage, back-up power, and PV self-consumption optimization.

The battery pack is composed of 16 cells of LFP batteries in series connection, with low self-discharge, high energy density, and no memory effect. This type of battery also has excellent performance in high rate, long cycle life, wide temperature range, and high safety.

#### ▶ 3.1.1 Features

- **High energy density**

Higher volume ratio energy and weight ratio energy.

- **Maintenance-free**

The battery pack is maintenance-free in the process of using, which can save customers' battery operation, maintenance testing costs and reduce the frequency of on-site replacement.

- **Long cycle life**

The battery pack life is 3 times long than the ordinary lead-acid batteries.

- **Excellent temperature characteristics**

When charging, the battery working temperature can reach 0°C~+60°C. (recommended using temperature: +15°C~+35°C). When discharging, the battery working temperature can reach -20°C~+60°C. (recommended using temperature: +15°C~+35°C).

- **Hot Aerosol Fire Extinguishing Device**

The special hot aerosol fire extinguishing device for lithium-ion batteries has the advantages of being highly efficient and rapid in extinguishing lithium-ion battery fires. When the lithium battery pack experiences thermal runaway and the temperature reaches 175°C±15°C the fire extinguishing device is promptly activated. Within 2 ~ 3 s, the fire is completely discharged and extinguished instantly.

#### ▶ 3.1.2 Basic Functions

- **Monitor**

- The battery system uses a high-performance BMS, it has protection functions such as current, voltage.

- **Alarm**

- Support abnormal alarms such as over voltage, under-voltage, over current, short circuit, high and low temperature, battery failure, hardware failure, etc.

- **Parallel connection application**

Max. support 15pcs batteries in parallel connection. (Recommendation: for better performance, when the number of batteries exceeds 2pcs, please connect all batteries to the bus-bar.)

- **Balance function**

Support the cells balance function.

### ▶ 3.2 Application Scenario

The battery pack is used to provide backup power, load shifting, peaking shaving and can be used for residential energy storage, solar energy storage and other application scenarios.

The normal working operation diagram of the battery pack can be as shown in the figure below.

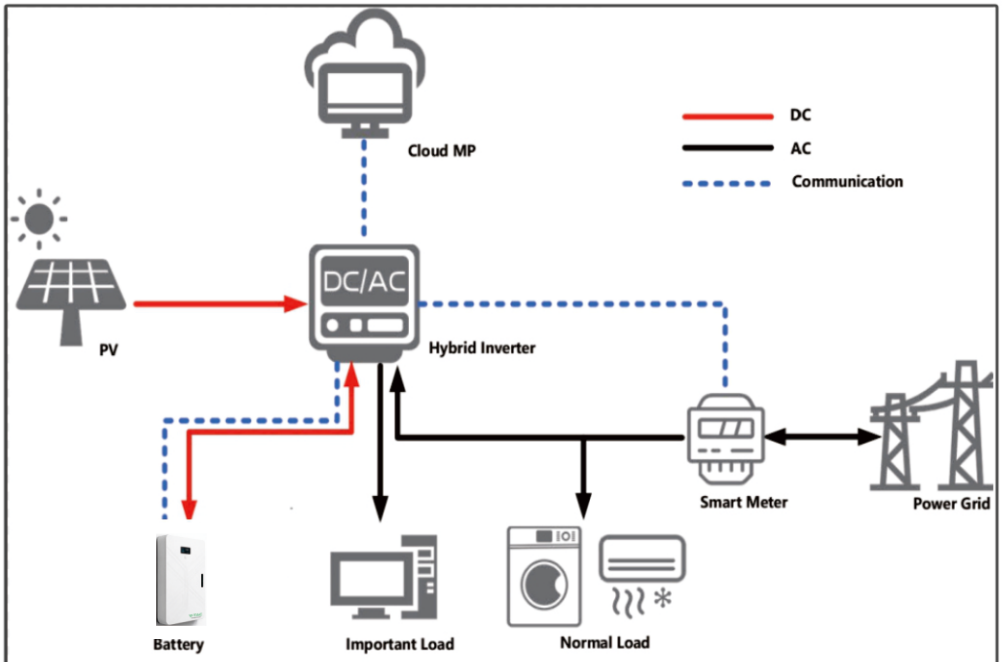
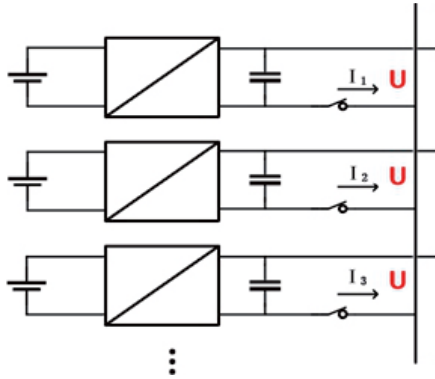

Fig. 3-1 Working Diagram of the Battery Pack

### ▶ 4.1 Parallel Connection Application



The battery packs support parallel connection, and synchronously increases the backup time or backup power.

Confirm the consistency between the battery packs, check the SOC and voltage and turn off the batteries before connecting them in parallel.

### ▶ 4.2 Low-temperature Application

#### • Low-temperature Charging

The battery pack does not support direct charging of the battery below  $0^{\circ}\text{C}$ . When the minimum temperature of the battery is below  $0^{\circ}\text{C}$ , the BMS will cut-off the charging circuit and cannot be charged.

#### • Low-temperature Discharging

The battery pack does not support discharge below  $-20^{\circ}\text{C}$ . When the minimum temperature of battery is below  $-20^{\circ}\text{C}$ , the BMS will cut-off the discharge circuit and cannot discharge.

### ▶ 4.3 Low Battery-capacity Storage (SOC $\leq$ 5%)

After the battery pack is power off, there will be BMS static power consumption and self-discharge loss. In actual scenarios, it is necessary to avoid low-battery-power state ( SOC $\leq$ 5% ) storage. If it is unavoidable, the longest storage period is 30days @ $25^{\circ}\text{C}$ , 15 days@ $45^{\circ}\text{C}$ . The battery needs to be recharged in time after storage, otherwise the battery may be damaged due to over-discharge, and the entire battery pack needs to be replaced.

### ▶ 4.4 Application of Nearing the Ocean

The atmospheric corrosion environment is defined and classified according to the natural environment state, and the A/B environment is defined as follows:

- A: environment refers to the ocean or the land near the pollution source, or the environment with simple shelter (such as awning). "Near the ocean" refers to the area 0.5 ~ 3.7km away from the ocean; "Near the pollution source" refers to the area within the following radius: 3.7km from the saltwater lake, 3km from heavy pollution sources such as smelters, coal mines, and thermal power plants, chemical industry, rubber, electroplating, etc. 2km from medium pollution sources such as chemical industry, rubber and electroplating, etc. And 1km from light pollution sources such as food, leather and heating boilers, etc.

- B: environment. Refers to the environment on land or outside with simple shelter (such as awning) within 500m from the coast, or the environment on the sea.

---

#### NOTE

The battery pack can be used under other environmental conditions and cannot be used alone under A/B environment. If it is to be used in the A/B environment, it needs to be equipped with a high-protection air-conditioning cabinet, which is recommended to be IP55 or higher.

---

## 5 Product Introduction

### 5.1 Dimensions

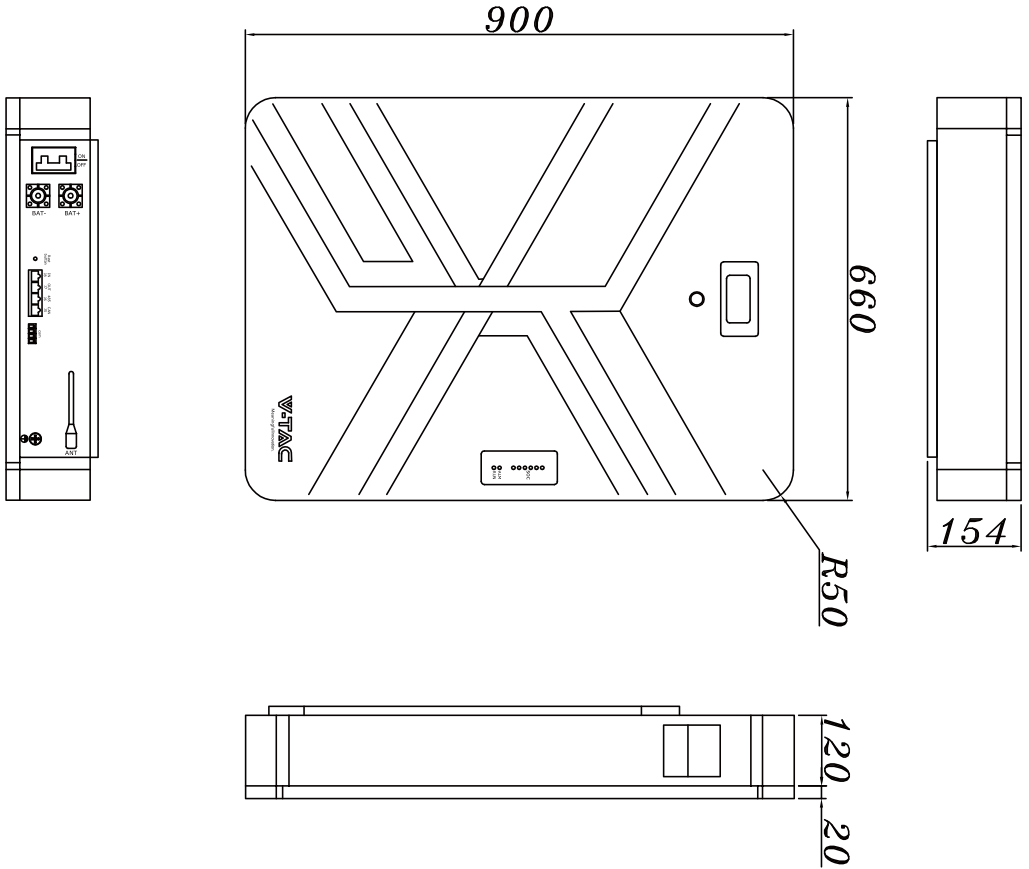
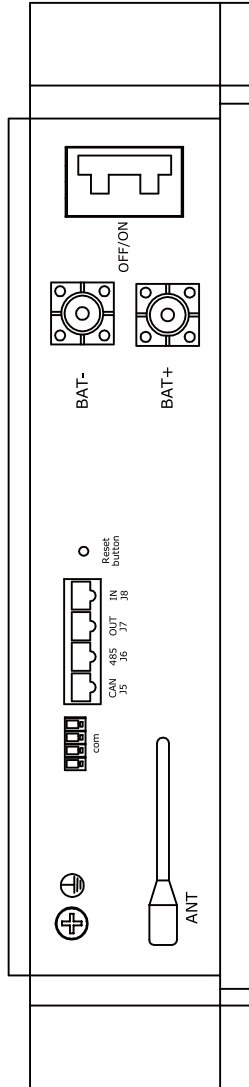
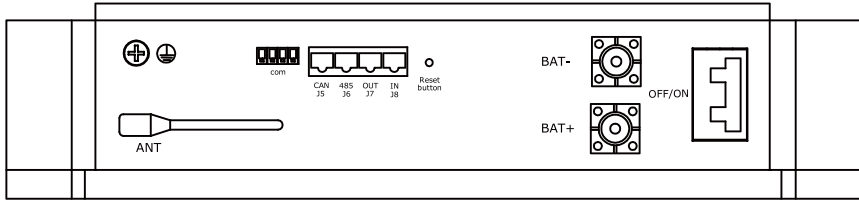

Fig. 5-1 Product Dimensions

## 5.2 Panel Introduction

The panel is shown as follows.





The definition of the VT-14033 operation panel is shown as follows.

Table 5-1 Operation Panel Interface Definition

Items	Remark	
soc	State of charge	
RUN/ALM	To indicate the running or alarm status of battery	
J5	J5 is used for communication with inverter can.	
J6	J6 is used for communication with inverter 485.	
J7	J7 is used for parallel output	
J8	J8 is used for communication between batteries, Parallel input and used for debugging BMS	
Reset button	Power on/Activate	In the dormant state, pressing the button for about 3 seconds activates it. After the LED indicator lights up in sequence, it transitions to the normal working state;
	Power off/Sleep	When the device is powered on, if you press and hold a button for 3 seconds before releasing it, the BMS will enter a sleep state. After the LED indicator lights up sequentially, it will also transition into a sleep state;
	Reset	When the device is powered on, pressing the button for 6 seconds will reset the BMS.
COM	When alarms and protection occur, a closed loop is formed here	
BMS SWITCH	When the key is pressed, the self-locking switch closes and the energy storage system starts. Press the button again to disconnect the self-locking switch and shut down the system.	
ANT	Receive blue tooth signal	

The SOC indicator used to identify the current capacity status of the battery.

The number of blinking indicators corresponds to different remaining capacity. The specific meaning is shown as follows.

Table 5-2 The Alarm Indicator Definition

Indication Status	ON	OFF	Battery Status
Keep On			Fault (Charge/Discharge MOS、NTC、ADC Fault, Reverse Connection Fault)
Keep Off			Standby/Sleep/No issue

Line specification :

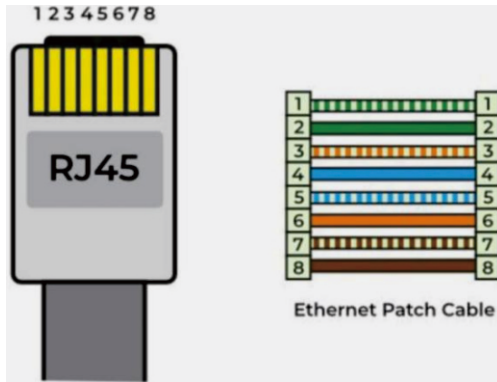

As shown in the figure: no buckle face up, from the top down, the line sequence is 12345678

# 5 Product Introduction

## 5.3 Definition of indicator light illumination sequence

Indicator							
●	●	●	●	●	●	●	●
L1	L2	L3	L4	L5	L6	L7	L8
SOC						Alarm	Running

state	Charge								
Capacity indicator	SOC	L1	L2	L3	L4	L5	L6	ALM	RUN
Capacity Scope%	0	Off	Off	Off	Off	Off	Off	Off	On
	$0 < \text{SOC} \leq 16$	Flash 2	Off	Off	Off	Off	Off	Off	On
	$17 \leq \text{SOC} \leq 32$	On	Flash 2	Off	Off	Off	Off	Off	On
	$33 \leq \text{SOC} \leq 49$	On	On	Flash 2	Off	Off	Off	Off	On
	$50 \leq \text{SOC} \leq 65$	On	On	On	Flash 2	Off	Off	Off	On
	$66 \leq \text{SOC} \leq 82$	On	On	On	On	Flash 2	Off	Off	On
	$83 \leq \text{SOC} < 100$	On	On	On	On	On	Flash2	Off	On
	100	On	On	On	On	On	On	Off	On
state	Discharge								
Capacity indicator	SOC	L1	L2	L3	L4	L5	L6	ALM	RUN
Capacity Scope%	0	Off	Off	Off	Off	Off	Off	Flash3	Flash3
	$0 < \text{SOC} < 10$	On	Off	Off	Off	Off	Off	Flash3	Flash3
	$10 \leq \text{SOC} \leq 16$	On	Off	Off	Off	Off	Off	Off	Flash3
	$17 \leq \text{SOC} \leq 32$	On	On	Off	Off	Off	Off	Off	Flash3
	$33 \leq \text{SOC} \leq 49$	On	On	On	Off	Off	Off	Off	Flash3
	$50 \leq \text{SOC} \leq 65$	On	On	On	On	Off	Off	Off	Flash3
	$66 \leq \text{SOC} \leq 82$	On	On	On	On	On	Off	Off	Flash3
	$83 \leq \text{SOC} < 100$	On	On	On	On	On	On	Off	Flash3
	100	On	On	On	On	On	On	Off	Flash3

## 5 Product Introduction

	Indicator light	LED1	LED 2	LED 3	LED 4	LED 5	LED 6	RUN	ALM	Buzzer sound
1	Environment H-T	OFF	OFF	OFF	OFF	OFF	OFF	OFF	ON	yes
2	Environment L-T	OFF	OFF	OFF	OFF	OFF	OFF	OFF	ON	yes
3	MOS High temp	OFF	OFF	OFF	OFF	OFF	OFF	OFF	ON	yes
4	Charge-Low temp Faults	OFF	OFF	OFF	OFF	OFF	OFF	OFF	ON	yes
5	Charge High temp Faults	OFF	OFF	OFF	OFF	OFF	OFF	OFF	ON	yes
6	Discharge-Lowtemp Faults	OFF	OFF	OFF	OFF	OFF	OFF	OFF	ON	yes
7	Discharge High temp Faults	OFF	OFF	OFF	OFF	OFF	OFF	OFF	ON	yes
8	Low voltage	OFF	OFF	OFF	OFF	OFF	OFF	OFF	Flash 3	NO
9	high voltage	ON	ON	ON	ON	ON	ON	ON	OFF	NO
10	Charge Over current	Based on battery level display						Flash 1	OFF	yes
11	Discharge overcurrent	OFF	OFF	OFF	OFF	OFF	OFF	OFF	ON	yes

Note: 1. "Failure" refers to abnormal charging and discharging MOS drive voltage, abnormal power supply voltage, charging and discharging MOS failure, AFE failure, NTC failure, cell failure, current sensor failure, precharge failure, and current limit failure.  
 2. "Alarm" refers to alarms triggered by low capacity, low cell voltage, low total voltage, overcurrent during charging, overcurrent during discharging, high cell temperature, low cell temperature, high ambient temperature, low ambient temperature, and high MOS temperature.  
 3. Buzzer action (configurable, only valid when configured to be on)  
 In case of a fault, it will sound for 0.25 seconds every second;  
 During protection, it will sound for 0.25s every 2s (excluding overvoltage protection);  
 When an alarm is triggered, it will sound for 0.25s every 3s (excluding overvoltage alarms);  
 The buzzer function can be enabled or disabled through the host computer, and it is disabled by default at the factory.

Meaning of buzzer and LED light When the battery is normal

Annotation :

Normal	Always	Extinct	According to the SOC display		No-loud	/
Noun explain		LED		Buzzer		
"Flash 1"		Bright0.25s ,extinguish3.75s				
"Flash 2"		Bright0.5s ,extinguish0.5s				
"Flash 3"		Bright0.5s ,extinguish1.5s				
In case of a fault				it will sound for 0.25 seconds every second		
During protection				it will sound for 0.25s every 2s		
When an alarm is triggered				it will sound for 0.25s every 3s		

## 6 Installation

### Precautions for Installation

- Light intensity is required near the installation location.
- Comply with the safety operation technical regulations when lifting and handling heavy objects.
  - Equipment and tools must be complete, intact, and reliable. It is strictly prohibited to use tools with cracks, burrs, loose handles, etc., that do not meet the safety standards.
  - Installation operations must be guided by qualified engineers
  - During installation, two people must work together, one operating and the other inspecting.
    - The original cable connection and operation process shall not change without the authorization of the company's consent.

#### ▶ 6.1 Installation Preparation

- Light intensity is required near the installation location.
- Comply with the safety operation technical regulations when lifting and handling heavy objects.
  - Equipment and tools must be complete, intact, and reliable. It is strictly prohibited to use tools with cracks, burrs, loose handles, etc., that do not meet the safety standards.
  - Installation operations must be guided by qualified engineers.
  - During installation, two people must work together, one operating and the other inspecting.
    - The original cable connection and operation process shall not change without the authorization of the company's consent.

#### ▶ 6.2 Installation Preparation

##### ▶ 6.2.1 Tools Preparation



#### ATTENTION













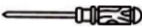

Use insulated tools to avoid electric shock. If you use tools without insulation protection, you need to wrap the exposed metal parts with insulation tape for insulation treatment.

---

# 6 Installation

The following table describes the tools and meters that may be used before installation.

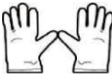
Table 6-1  
Installation

Manual forklift	Electric forklift	Tape measure	Adjustable wrench
			
Phillips screwdriver	Ladder	Levelling Instrument	Claw Hammer
			
Socket wrench	Multimeter	Insulated torque wrench	Helmet
			
Insulated shoes	Anti-static gloves	Goggles	Insulating tape
			

## 6.3 Packing List

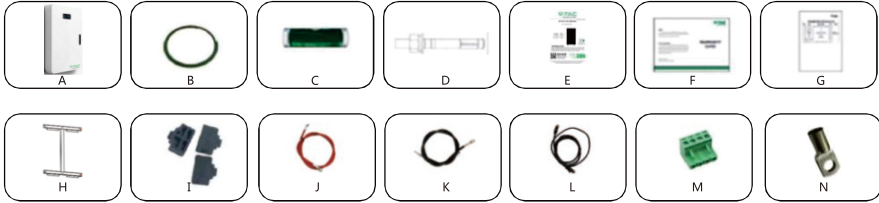

Item	Description	Quantity
A	VT-14033 battery	1
B	GND cable	1
C	Spirit Level	1
D	Fixin g Screws ( Expansion Bolt )	6
E	User Manual	1
F	Warranty Card	1
G	Packing List	1
H	Bracket	1
I	J5 J6 J7 J8Dust-proof plug	4
J	2m positive power cable,battery-inverter	1
K	2m negative power cable,battery-inverter	1
L	2m battery-inverter(CAN Communication)	1
M	Dry contact cornektor	1
N	Copper Lug SC50-8	2

## 6.4 Unpacking and Inspection

After receiving the goods on-site, please check whether the packing box is intact and inspect the goods in time. If the packing box is slightly damaged, please sign the cargo list to confirm receipt and indicate the extent of the damage. If the damage of the packing box is serious, please refuse to sign

Please carry out an unpacking inspection after receiving all the goods. If users find that the received goods do not match the packing list, please contact Vtac as soon as possible.

## 6.5 Installation

Step 1. Place the battery to a flat surface.

### NOTE

- Please place the VT-14033 battery on a flat surface, ensuring there is adequate space on both sides of the battery (recommended to be greater than 200mm).
- If possible, the installation site should be as spacious and ventilated as possible. If the site is small and confined, please configure auxiliary heat dissipation equipment.

To ensure more stable installation, please mount the battery to the wall before use.

Step 2. Take out the bracket from the battery package

Step 2.1. Remove the bracket from the battery pack.

Step 2.2. Fix the bracket to the wall.

Step 2.3. Hang the battery pack on the bracket.

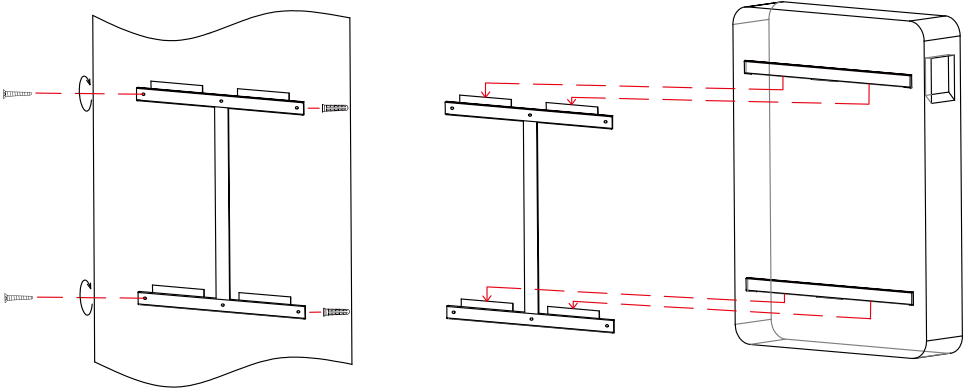

Fig.6-1 Fix the Brackets to the Battery

## 6 Installation

Step 3. Fix the 2pcs\* 'Fixing screws' on the wall.

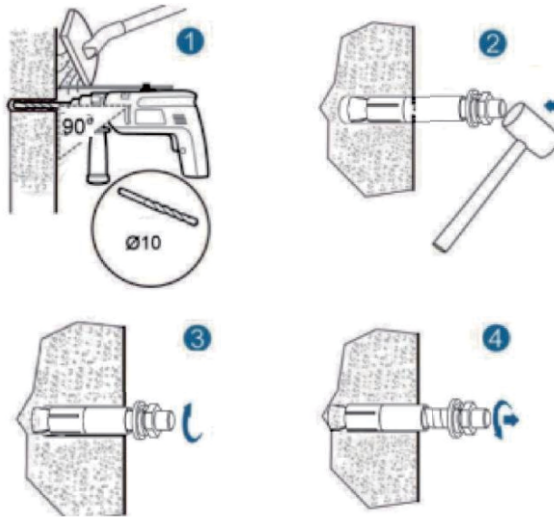

Fig.6-2 Fix the Battery to the Wall

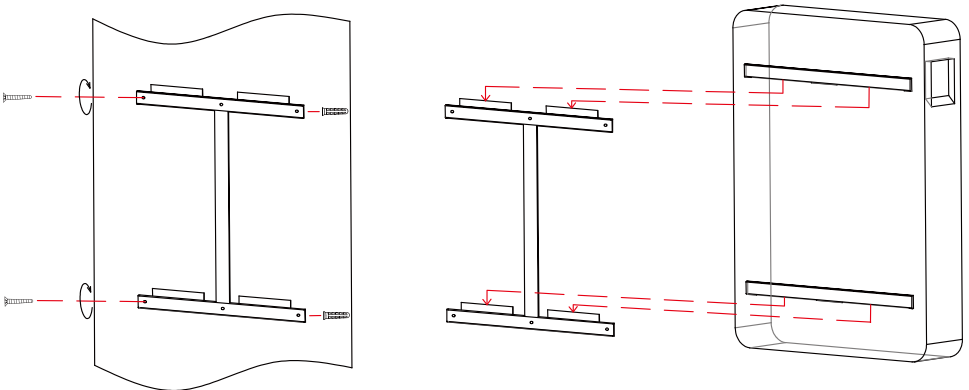

Fig.6-3 Fix the Battery to the Wall

## 6 Installation

### ▶ 6.6 Cable Connection

#### ▶ 6.6.1 Power Cable Connection

#### NOTE

- Please contact Vtac or the supplier to purchase the following cables . They are maybe not included in the battery box and can be obtained in the Master/Slave Cable Kit provided by Vtac or the suppliers

- How to use the touch-safe power cable connectors

Press the unlock on the power cable while inserting the power cable into the socket.

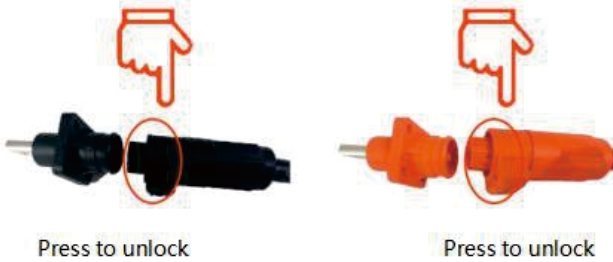

The following is the power cables connection display of the battery to the inverter.

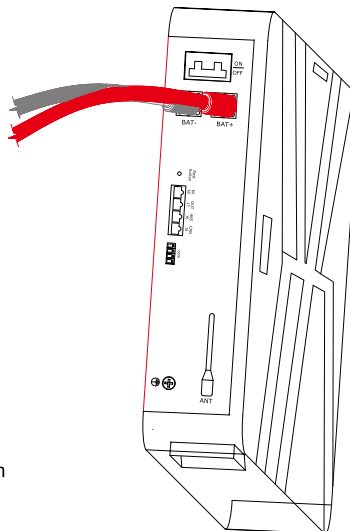

Fig.6-4 Power Cable Connection Diagram

### ▶ 6.6.2 Communication Cable Connection

Locate the direction of the communication cable with the socket and then insert the communication cable to the socket.

---

#### 📌 NOTE

- How to use the communication cable connectors

Open the communication port cover, align it with the corresponding socket, and insert it.

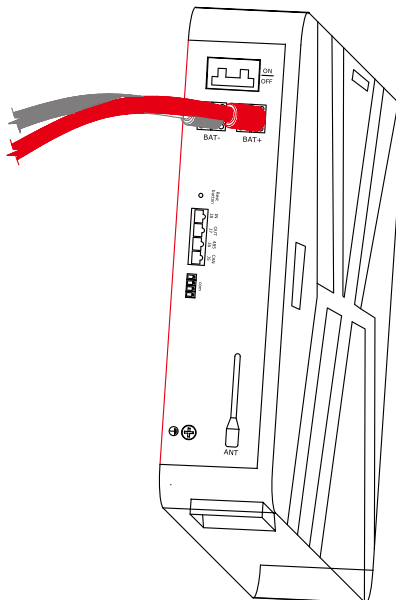

6-5 Communication Cable Connection Diagram

## 6.6.3 Grounding Cable Connection

Connect the grounding cable to the ground

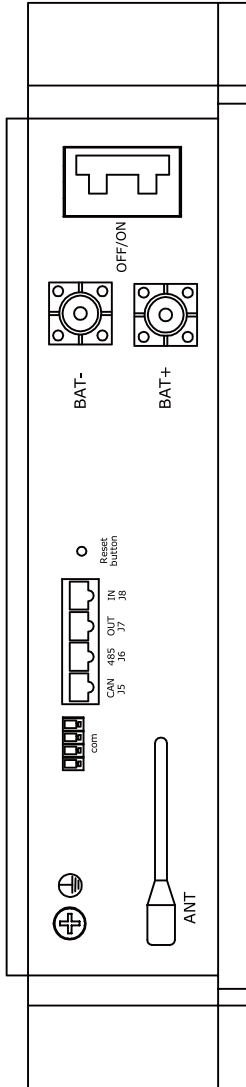
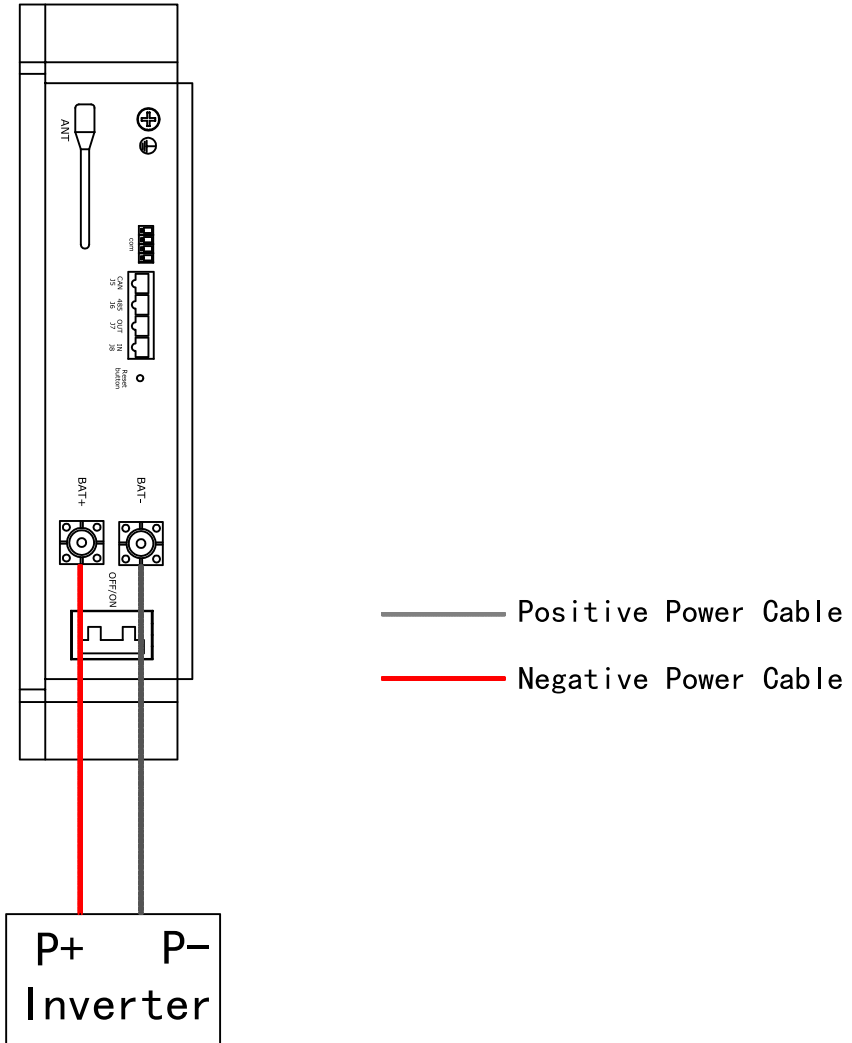

Fig.6-6 GND Cable Connection Diagram

## 7 Parallel Connection

If you will install less than 2pcs batteries (Battery quantity 2), please refer to the following wiring configuration.

Battery Quantity of Parallel	Cable Kit
1 PC	Master Cable Kit * 1 set



## 7 Parallel Connection

If you will install more than 2pcs batteries (No more than 15pcs), you will have the following two system wiring options

Option 1. Connect all batteries to the bus bar.



### NOTE

- For this wiring solution, you will need to prepare bus bars and power cables to connect the bus bars to the inverter in addition . You can either purchase them independently or obtain them from Vtac or the supplier .

- In this wiring solution .the maximum allowable charging current for a single battery is between the charging alarm and the alarm recovery value . (Taking 140 ah as an example , the alarm value and the alarm recovery value are 140-130 respectively , and the requested current is 140 A . ) bFor instance , when three units are connected in parallel , the maximum allowable charging current is 90% of the sum of the maximum allowable charging currents of each individual unit ( $140 \times 3 \times 0.9 = 378A$ )  
Discharging is the same

Battery Quantity of Parallel	Cable Kit
3 PCS	Master Cable Kit * 3 set
N PCS ( 45N<15 )	Mast er Cable Kit * N set ( 4 N<15 )
15 PCS	Master Cable Kit * 15 set

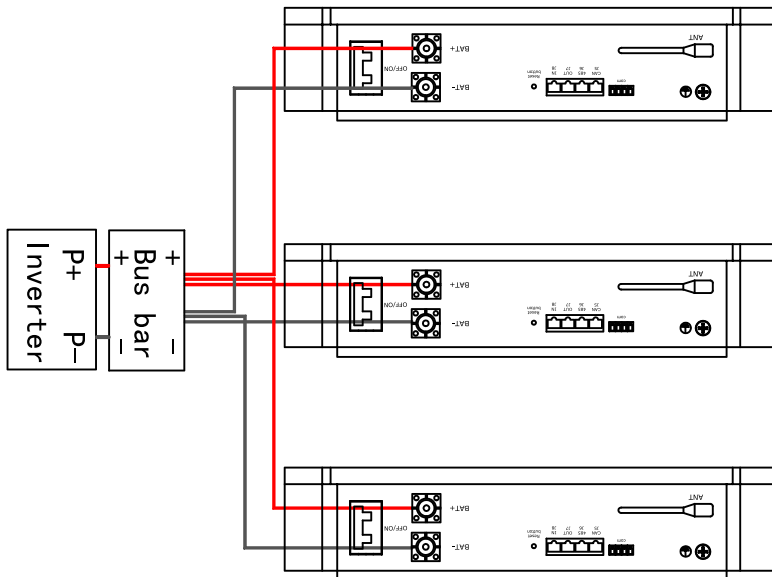

# 7 Parallel Connection

 **ATTENTION**

- If you will install more than 2pcs batteries (Contains 2, no more than 15 pcs), you need to pay attention to the connection of the parallel interface(J5).

If you will install more than 2pcs batteries , be sure to connect from the output of the last J5 to the input of the next J5. To avoid damaging to the BMS.

The connection diagram is as follows.

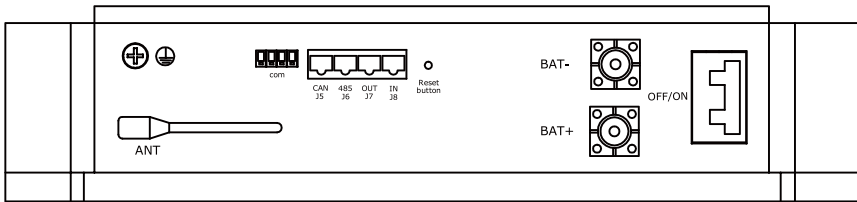

When the line diagram comes out, the main unit J7OUT is connected to the slave unit J8IN for input

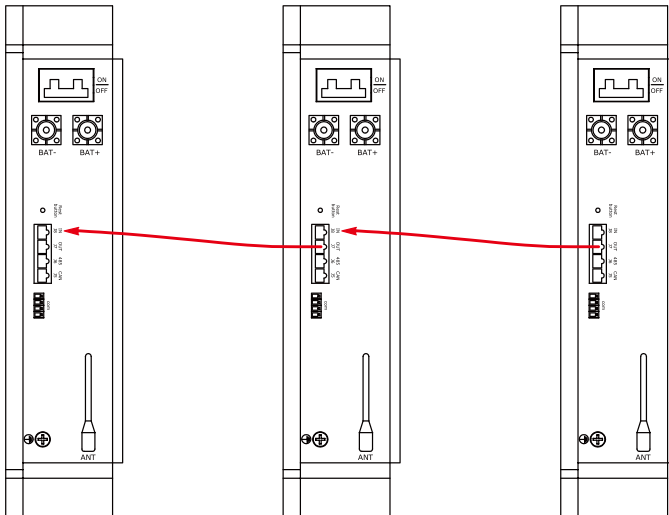

# 7 Parallel Connection

## The Communication Port Definition

RS485 and CAN communication  
Parallel and PCS communication interfaces, utilizing RJ45 sockets:

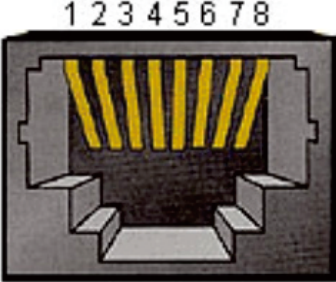
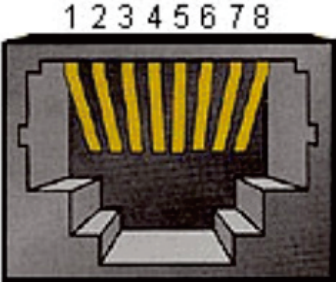
Pin	Definition Description	Port description	top view
1	DI-B(RS485B)	Parallel operation and PCS interface IN (uplink port)	
2	DI-A(RS485A)		
3	Communication SGND		
4	CANH		
5	CANL		
6	Communication SGND		
7	RS485-A		
8	RS485-B		
1	DO-B	Parallel operation interface OUT (downlink port)	
2	DO-A		
3	SGND		
4	CANH		
5	CANL		
6	SGND		
7	RS485-A		
8	RS485-B		
1	RS485-B	PCS interface (RS485)	
2	RS485-A		
3	Communication SGND		
4	NC		
5	NC		
6	Communication SGND		

## 7 Parallel Connection

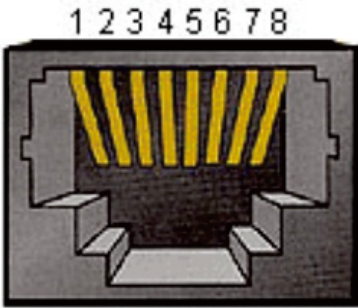
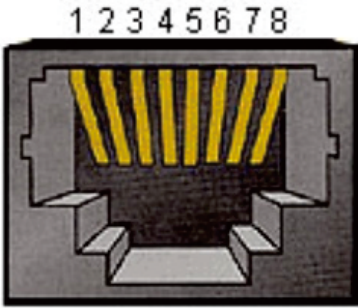
7	RS485-A		
8	RS485-B		
1	NC	PCS interface (CAN)	
2	NC		
3	SGND		
4	CANH		
5	CANL		
6	SGND		
7	NC		
8	NC		

CAN serves as the communication bus for inverters and battery master/slave devices, used for:

- ① inverters polling battery information;
- ② BMS master devices reporting aggregated information; and
- ③ inverters broadcasting upgrades to various BMS master and slave devices.

## 8 Make Your System Run

### ATTENTION

• Please strictly follow the steps below for check and operation. Vtac will not be responsible for any issues caused by improper operation.

---

#### Parameter Setting

Table 8-1 Parameter Setting

No.	Description	Unit	Value
1	Nominal Voltage	V	51.2
2	Float Charge Voltage	V	57.6
3	Recommended Charge Current	A	130
4	Max. Charge/Discharge Current	A	140
5	Discharge Cut-off Voltage	V	43.2
6	Charge Temperature Range	℃	0 - 60
7	Discharge Temperature Range	℃	-20 - 60
8	Storage Temperature Range	℃	15-35
9	working Temperature Range	℃	0-60
10	Rated Capacity	Ah	280
11	Nominal Energy	kWh	14.33
12	Communication	/	CAN
13	Cycle Life ( @ 25°C DOD90% )	/	≥8000
14	End of Life (@ 25°C EOL80 %)	/	≥8000
15	Protection Level	/	IP20

#### NOTE

- The setting of different inverters will be different.
  - Make sure the inverter/charger is powered on before powering on the battery.
  - Must not change the parameters casually in the site
-

### Check before Running

**Step 1.** Check whether the cables are connected correctly.

**Step 2.** Check whether the batteries are grounded.

**Step 3.** Check these following status of switch.

The power switch of the battery should be off.

The DC switch of the inverter should be turned on.

The circuit breaker from the inverter to the grid should be off.

The photovoltaic switch is off (if any) Open the circuit breaker of the battery (if any)

### Power-on

**Step 4.** Turn on the power switch of the battery. At this point, the inverter is powered on by the battery. Wait for 30 seconds until the system operates normally, then turn on the switches at the power grid and photovoltaic ends.

---

#### NOTE

- **If you want to *Power off* your system**

If you need to shut down the system for some reason, please refer to the following steps.

**Step 1.** Turn off the inverter first.

**Step 2.** Turn off the battery then.

---

## 9.1 Shipment

It is suitable for the transportation of vehicles, ships and airplanes. During transportation, shading, sun protection and civilized loading and unloading should be performed. The box containing the product is allowed to be transported by any means of transportation. In the process of loading and unloading, the battery should be handled with care to prevent falling, rolling, and heavy pressure. Avoid direct rain and snow and mechanical impact during transportation.

And here is the suggestion for the initial SOC before shipment by different transportation:

- Airplane:30%-50%
- Sea:40%- 50%
- Vehicle: 50%-60%



### NOTE

- Whether the loading SOC status of the battery is allowed, you need to consult the relevant government transportation department.

## 9.2 Maintenance

### 9.2.1 Battery Maintenance Considerations

When maintaining the battery, it is required to use insulated tools or wrap the tools in insulation.

- DO NOT place any debris on the top of the battery. DO NOT use any organic solvents to clean the battery. DO NOT smoke or use naked flames near the battery.
- After the battery is discharged, the battery should be charged in time to avoid affecting the battery life.
- when not using the battery for a long time, please charge the battery to 40%-50% charged state. Long-term storage with low battery may damage the battery.

All maintenance work must be carried out by professionals .

## ▶ 9.2.2 Routine Maintenance

The staff should perform visual inspection on VT-14033 battery according

To the inspection plan, please refer to the following table for maintenance.

Table 9-1 Routine Maintenance ( Every three-month )

Items	Standard	Dealing
Battery Appearance	<ul style="list-style-type: none"> <li>● The surface is neat and clean without stains.</li> <li>● The terminals are in good condition.</li> <li>● The battery pack shell is intact, and there is no bumps, breaks, or leakage.</li> <li>● The appearance of the battery pack does not leak.</li> <li>● No deformation or swelling of the shell.</li> </ul>	<ul style="list-style-type: none"> <li>● If the surface is dirty, clean the appearance of the battery pack with a cotton cloth.</li> <li>● The battery pack terminal is damaged, replace the cable.</li> <li>● If the appearance is damaged, leaking or deformed, take a photo and replace the defective battery pack.</li> <li>● Please contact supplier or the authorized dealers in time for other abnormal situations.</li> </ul>
Alarm	<ul style="list-style-type: none"> <li>● No Alarm.</li> </ul>	<ul style="list-style-type: none"> <li>● Find the solution as per alarm information.</li> </ul>

### NOTE

- Suggested routine maintenance for every three-month.

Table 9-2 Routine Maintenance (Every six-month)

Items	Standard	Action
( Suggested ) Complete Cycle	<ul style="list-style-type: none"> <li>• Have a complete charge &amp; discharge cycle under the equipment no lack of power</li> </ul>	<ul style="list-style-type: none"> <li>• Check whether happens alarm action, and please check with the alarm list</li> <li>• Please contact with supplier or the authorized dealers if the alarm still exists</li> </ul>
Cables	<ul style="list-style-type: none"> <li>• There is no aging of the connecting wire and no cracking of the insulation layer</li> <li>• The bolts at the cable connection are not loose</li> </ul>	<ul style="list-style-type: none"> <li>• Replace the faulty connection</li> <li>• Fastening bolts</li> </ul>

### 9.3 Battery Storage

- The recommended storage temperature is 15°C-35°C.
- Battery performance degradation after long-term storage, please shorten shelf time as possible as you can.
  - Recharge charge before using to recover capacity loss of self-discharge during storage and transport.
  - Storage battery should be at 40%-50% SOC when the battery is not used for a long time.
    - Storage battery over 40°C or under 0°C will reduce battery life.
    - Storage battery in dry and low temperature, well ventilated place.

If the battery is not used for a long time, the battery must be charged at regular interval s. The charging requirements are as follows :

Table 9-3 Battery Charge Requirement in Storage Status

Storage Temp.	Charge Period	Charge Process
20°C-30°C	Each 6 months	1.Charge by 0.2C to 100% SOC 2.Discharge by 0.2C to 0% SOC 3.Charge by 0.2C to 40%-50% SOC
0°C- 20°C or 30°C-40°C	Each 3 months	

Please refer to the table below to deal with common faults :

Table 10-1 FAQ

Phenomenon	Possible cause	Solution
The indicator does not flash	<ul style="list-style-type: none"> <li>● The power cable of the battery pack is not properly connected.</li> <li>● The power switch is off.</li> <li>● The BMS is in a sleep state.</li> <li>● BMS is damaged.</li> </ul>	<ul style="list-style-type: none"> <li>● Reconnect the power cable of the battery pack.</li> <li>● Turn on the power switch.</li> <li>● Charge the battery pack.</li> <li>● Replace BMS.</li> </ul>
Unable to discharge	<ul style="list-style-type: none"> <li>● The terminal of the battery pack is damaged.</li> <li>● BMS communication failure.</li> <li>● The power switch is off.</li> </ul>	<ul style="list-style-type: none"> <li>● Replace the battery pack wiring terminals.</li> <li>● Reconnect the communication line between the BMS and the battery pack. If the communication cable is damaged, replace the communication cable.</li> <li>● Turn on the power switch.</li> </ul>
Unable to charge	<ul style="list-style-type: none"> <li>● The charger is malfunctioning.</li> <li>● The terminal of the battery pack is damaged.</li> <li>● BMS communication failure.</li> <li>● The power switch is off.</li> </ul>	<ul style="list-style-type: none"> <li>● Replace the charger.</li> <li>● Replace the battery pack wiring terminals.</li> <li>● Reconnect the communication line between the BMS and the battery pack. If the communication cable is damaged, replace the communication cable.</li> <li>● Turn on the power switch.</li> </ul>
Communication fail	<ul style="list-style-type: none"> <li>● The power switch is off.</li> <li>● The BMS is in a sleep status.</li> <li>● The communication cable is damage.</li> </ul>	<ul style="list-style-type: none"> <li>● Turn on the power switch.</li> <li>● Charge the battery pack.</li> <li>● Replace the network cable.</li> </ul>
Inaccurate voltage display	<ul style="list-style-type: none"> <li>● The voltage sampling line is damaged.</li> <li>● BMS is damaged.</li> </ul>	<ul style="list-style-type: none"> <li>● Replace the voltage sampling line.</li> <li>● Replace BMS.</li> </ul>
Low capacity	<ul style="list-style-type: none"> <li>● The battery pack has not been maintained for a long time.</li> <li>● The single battery is damaged.</li> <li>● Inaccurate voltage sampling.</li> </ul>	<ul style="list-style-type: none"> <li>● Use an equalizer to maintain the battery pack.</li> <li>● Replace the damaged single battery.</li> <li>● Replace the electrical sampling line or replace the BMS.</li> </ul>
Low cell voltage	<ul style="list-style-type: none"> <li>● The battery pack has not been maintained for a long time.</li> <li>● The single battery is damaged.</li> <li>● Inaccurate voltage sampling.</li> </ul>	<ul style="list-style-type: none"> <li>● Use an equalizer to maintain the battery pack.</li> <li>● Replace the damaged single battery.</li> <li>● Replace the electrical sampling line or replace the BMS.</li> </ul>

Except for the following and the conditions specified in the contract, you can go to the supplier or the authorized dealers for reasonable warranty and maintenance .

1. Failure of equipment caused by unauthorized disassembly and maintenance operations without the supplier or the authorized dealers is not within the scope of the warranty.
2. Equipment damage caused by negligence during storage and transportation is not covered by the warranty.
3. The damage to the equipment caused by continuous overload work outside the electrical parameters of the equipment is not covered by the warranty
4. Unauthorized testing of the equipment without the supplier and the authorized dealers will not be covered by the warranty.
5. Non-equipment problems, adverse consequences caused by operation and matching problems are not covered by the warranty
6. Equipment damage caused by natural forces, force majeure, and out of control factors, such as earthquakes, typhoons, tornadoes, volcanic eruptions, floods, lightning, heavy snow, and wars, is not covered by the warranty.
7. If the product serial number is changed, blurred, or torn, it is not covered by the warranty.

## 12 Abbreviations

BMS	Battery Management System
D	Depth
H	Height
W	Width
LCD	Liquid Crystal Display
LFP	LiFeP04
MOSFET	Metal-Oxide-Semiconductor Field-Effect Transistor
NTC	Negative Temperature Coefficient
PC	Personal Computer
PCB	Printed Circuit Board
PCS	Power Conversion System
RTU	Remote Terminal Unit
SOC	State of charge

**RoHS**



# 13.Screen instructions

## Operating the LCD Interface

### 1、 Home



After the battery is turned on, enter the Home main interface, the displayed contents include V, I and SOC. (If you do not perform operations for more than 1 minute, the control screen went to rest mode). Tap the screen to wake up the interface.

Interface	Abbreviation of name	Full name
Home		Voltage
		Current
		State Of Charge
		Battery/System status
		Press to enter settings

### 2、 Menu

Press the three lines on the top right corner of screen to enter Menu

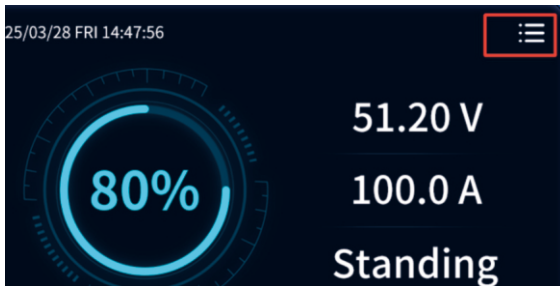

The Menu interface will look like as the image below:



### 3、 State

To see the battery detailed parameters like Mos Temperature, SOH, SOC, capacity, voltage, current, Address of battery and number of parallel connected batteries you can see in the State option in settings.

After you enter in Menu press the **"STATE"**

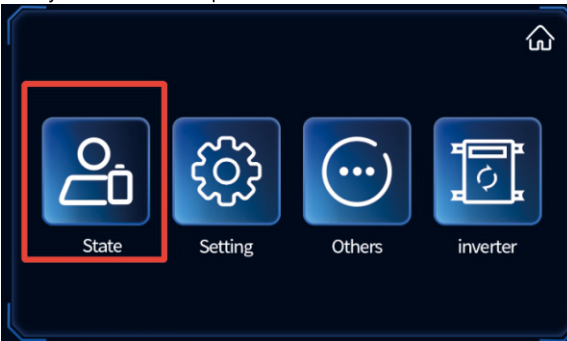

After this you can see an interface with the detailed battery state which contains additional parameters of battery state.



If you press the twin arrows  on the screen then you can see additional information related to parallel connection of battery.



If you want to go back to previous page just press the revert icon to go back.

### 4. Inverter communication protocol Selection

To select a communication protocol for inverter (RS485/CAN) you can enter the inverter section.

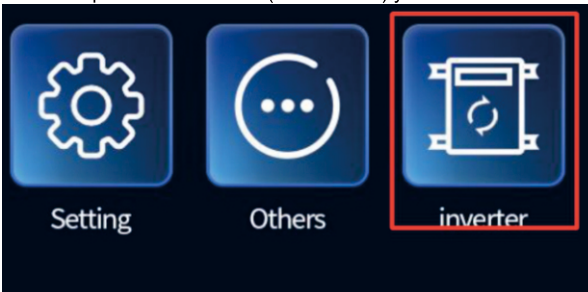

It will open a interface and here you can select between the RS485 or CAN. As Shown in image below.

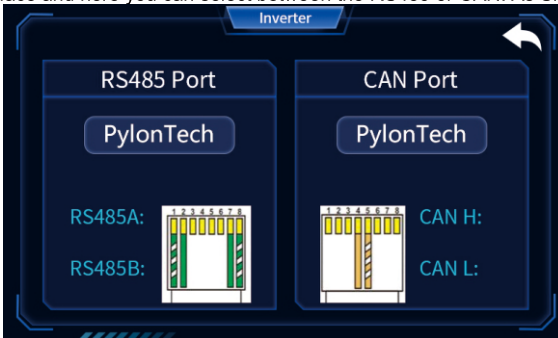

After selecting one of them you need to select the brand of inverter. Press on the inverter brand as per you need. If you are using the CAN then press the brand name icon on CAN port .

If you are using RS485 then select the brand name on the RS485 port. .

# 13.Screen instructions

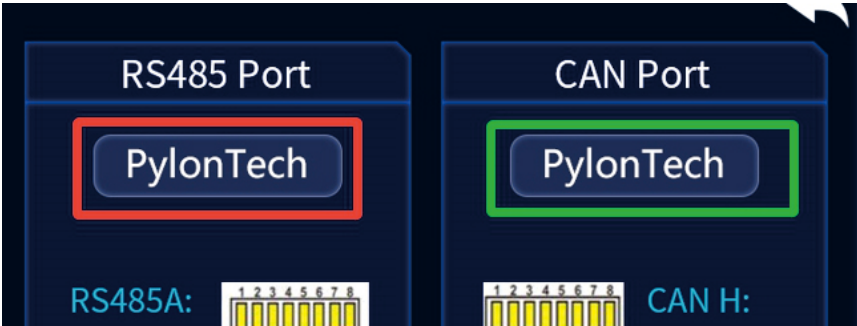

After it you can select the Inverter brand.

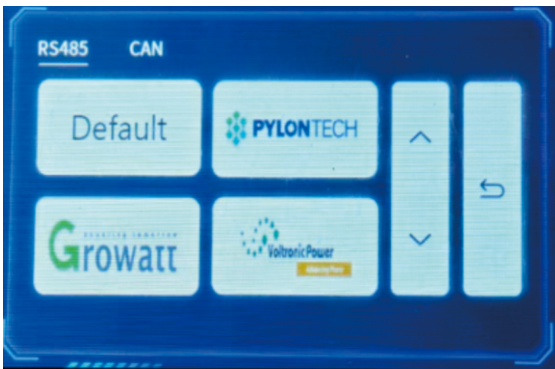

To see more inverters in the list press the up or down button and select the relevant inverter.

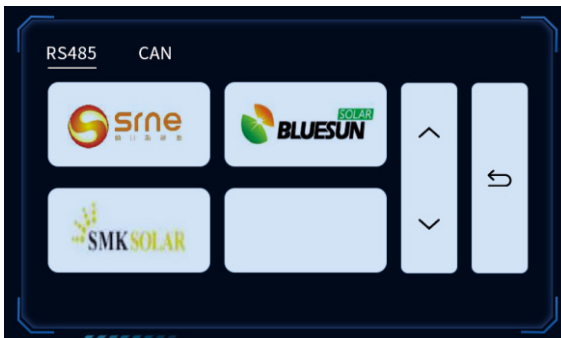

# 13.Screen instructions

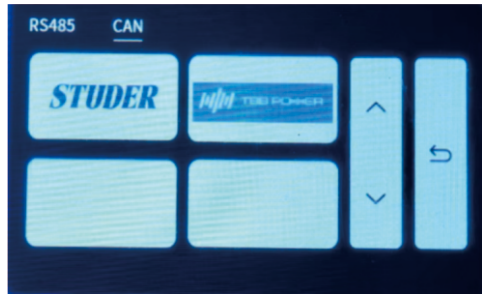

## 13.Screen instructions

To return to menu just press the return button. 

### 5、 Battery Cell details

To see the battery cell voltage, battery cell temperature, MOS temperature press the “Others” after entering menu. As shown in image below

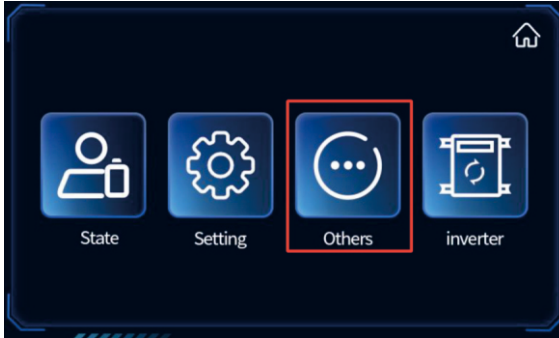

Here you can see all the detailed parameters

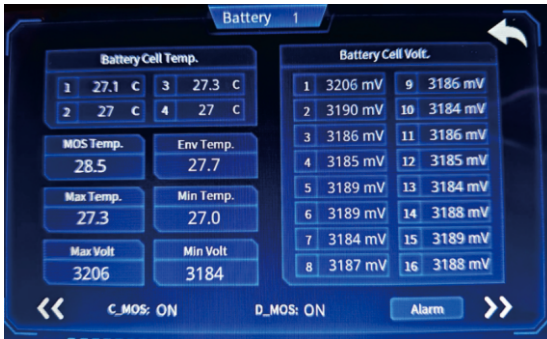

To see the Alarm details press the Alarm button  on this interface. Here you can see the list of all alarms.

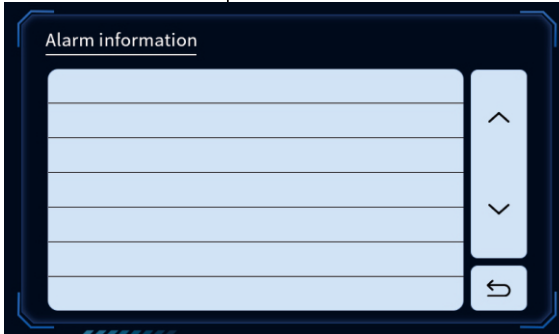

And to go back to previous page press the return button. 

# 13.Screen instructions

## 6、 Brightness settings



To set the brightness and see the parallel number of battery select the settings button.

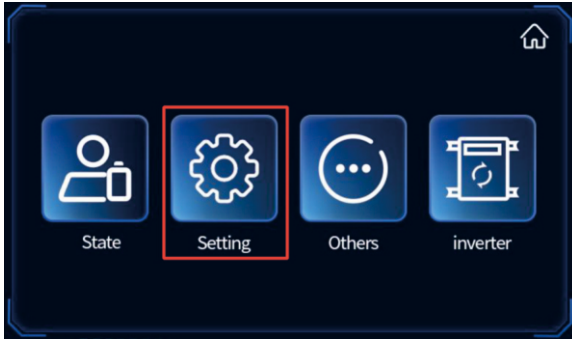

Here you can change the brightness and details of parallel battery.



## 7. Year, month, day and time adjustment

1、 Click on the year, month, day and time range that need to be adjusted



## 13. Screen instructions

2. After the enlarged area appears, click the place you need to adjust again.

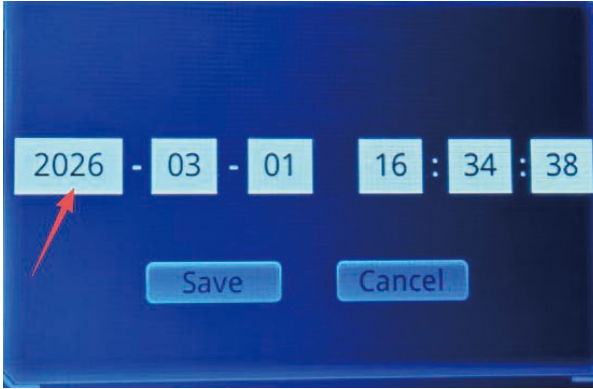

3. Enter the correct year, month, day and time, and press "↵" to confirm

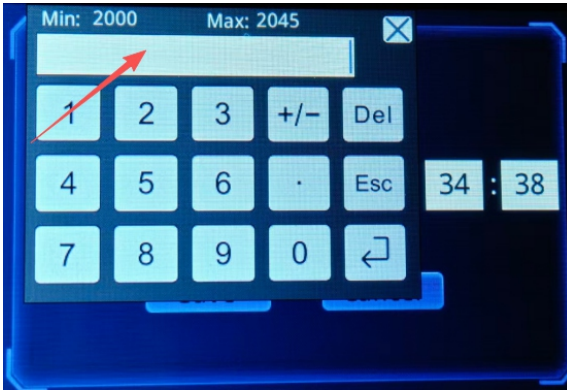

4. After making the modifications, press "Save" to save it, and then press "Cancel" to exit.

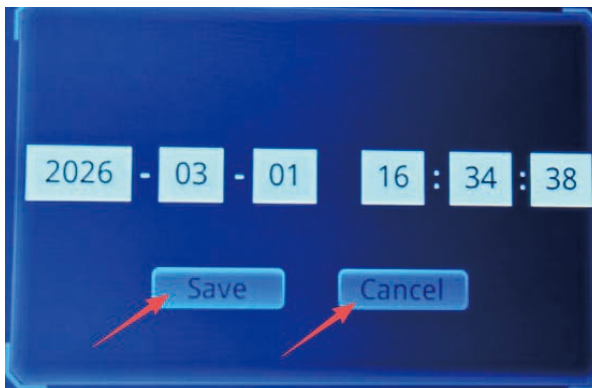

## 14. Wireless module instructions (APP)

### 1. App Introduction

TBESS App - Your Smart Home Energy Storage Butler

A mobile application designed specifically for home energy storage devices (hereinafter referred to as "home storage"), which enables remote control and data management through Bluetooth/Wi Fi, making energy control easier.

Core functions:

- Real time monitoring:
  - View key data such as device operating status, battery level, voltage, current, etc
  - Obtain software and hardware version information and abnormal alarm reminders
  - Generate charge and discharge statistics to assist in energy efficiency analysis
- Intelligent control:
  - One click firmware upgrade to continuously improve device performance
- Family sharing:
  - Multi member device permission sharing, making the household's electricity usage situation clear at a glance
- Service support:
  - Quickly submit usage feedback and connect directly to professional after-sales service
- Connection method:
  - Bluetooth (close range operation)
  - Wi Fi (remote control)

#### 1.1. Accompanying products

The TBESS App is suitable for the home storage series products of TB Energy Storage.

#### 1.2. Download and Install App

Mobile phone requirements:

1. Mobile operating system requirements: Android version 7.0 or above, iOS version 13.0 or above.
2. The mobile phone supports a web browser and connects to the Internet.
3. The mobile phone should supports WLAN/Bluetooth.

Method 1: Search for TBESS on the App Store (iOS) or Google Play (Android) to download and install it.

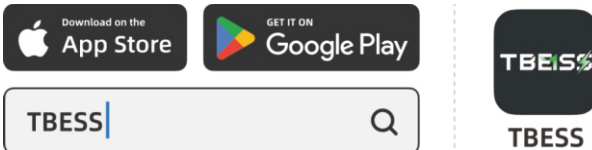

Method 2: Scan the QR code below to download and install.

# 14. Wireless module instructions(APP)



## 2. Login/Register/Forgot Password

### 2.1. Login



Figure 1

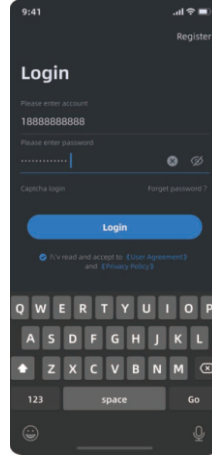

Figure 2

- 1)Figure 1: After launching the app, it automatically enters the login page.
- 2)Figure 2: Registered users enter their account and password, check their agreement with the relevant agreement, and then click **"Login"** .

### 2.2. Register

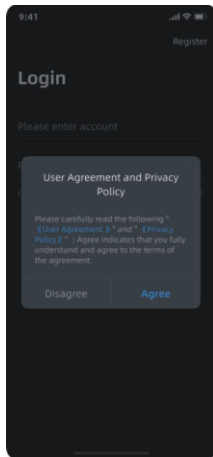

Figure 1

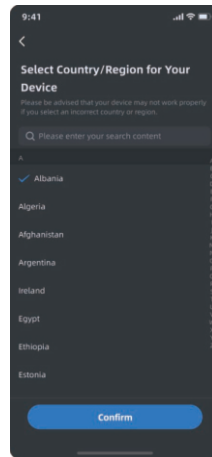

Figure 2

- 1)Figure 1: Unregistered users click on **"Register"** on the login page, read and click on the **"Agree"** agreement, proceed to the next step.
- 2)Figure 2: Select the country/region where the device will be used and click **"Confirm"**.

## 14. Wireless module instructions(APP)

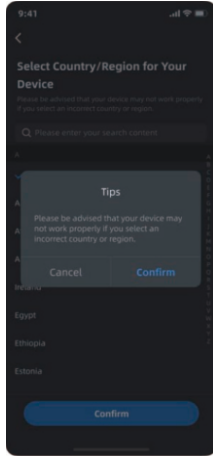

Figure 3

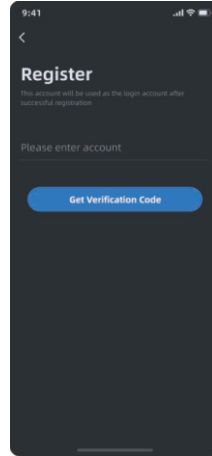

Figure 4

3 )Figure 3: Prompt "Select Country/Region for Your Device", click "Confirm" to enter the registration page.

4 )Figure 4: Enter the account and click "Get Verification Code" to enter the verification code page.

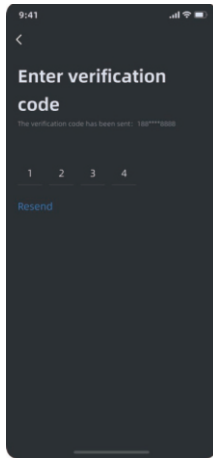

Figure 5

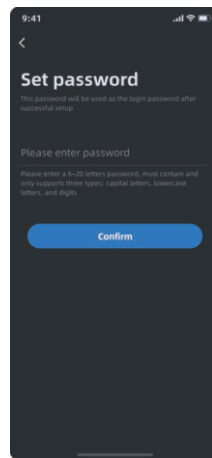

Figure 6

5 )Figure 5: After entering the verification code, enter the password setting page.

6 )Figure 6: Enter the required password and click "Confirm" to complete the registration.

Important note : China supports mobile phone number or email registration, while overseas only supports email registration.

## 14. Wireless module instructions(APP)

### 2.3. Forget password

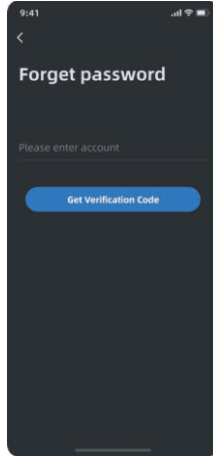

Figure 1

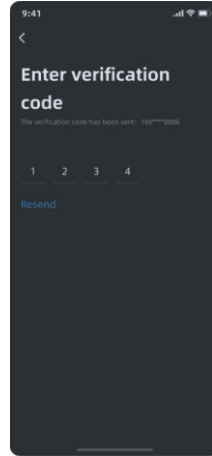

Figure 2

- 1) Figure 1: If you forget your password, you can reset it through "**Forgot Password**". Click "**Forgot Password**" on the login page, enter your registered account and click "**Get Verification Code**" to enter the verification code page.
- 2) Figure 2: After entering the verification code, enter the password setting page.

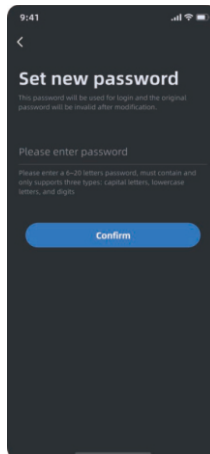
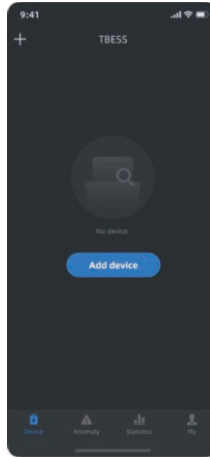

Figure 3

- 3) Figure 3: Enter the new password that meets the requirements and click "**Confirm**" to log in.

## 14. Wireless module instructions(APP)

### 3. Add Device



After logging in to your account, you can click on "**Add Device**" or the "+" in the upper left corner to enter the add device page. There are three ways to add devices: Bluetooth add, manual add, and scan code add. The default is Bluetooth add.

Important Notice:

1. **When adding an using Bluetooth**, please ensure:

- Home storage is activated
- The distance between mobile phone and home storage is within 5 meters
- If there are multiple home storage devices of the same model around, please compare **the last six digits of the Mac device** in the displayed device list with **the last six digits of the Mac device** on the label of the home storage body to be bound, and select the device that matches perfectly for connection
- Use the 2.4GHz band. If the router has dual bands, it is recommended to separate and select the 2.4G network
- Stable WiFi signal, speed test recommendation: upload/download  $\geq 2\text{MB/s}$  or 16Mbps
- Enter the correct WiFi password, case-sensitive/space-sensitive
- The number of devices connected to the router is not exceeded, or other devices are temporarily turned off
- If the router has wireless Mac address filtering turned on, please turn off or add the device MAC address
- If you are using iOS14, please go to "Settings → APP → Turn on local network permissions"

2. If there is connection failure:

- Restart the Bluetooth function of the phone and try again
- Try to restart the device or change the 2.4GHz WiFi to reconnect the network
- You can also switch to scanning or manually adding

## 3.1. Add device by Bluetooth

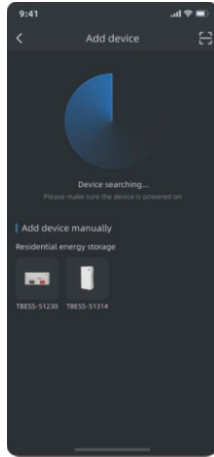

Figure 1

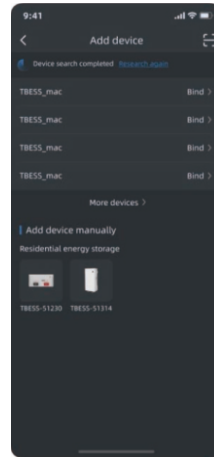

Figure 2

- 1) Figure 1: After enabling Bluetooth on the phone, start searching for Bluetooth signals from surrounding devices and try to add them **as close to the device as possible**; You can also click on **"manually add"** or **"scan code to add"** to switch the additional method.
- 2) Figure 2: Display the list of searched devices, select the device to be added, click **"Bind"** to start adding the device; If no device is found, you can click **"Research again"** or use other ways to add it.

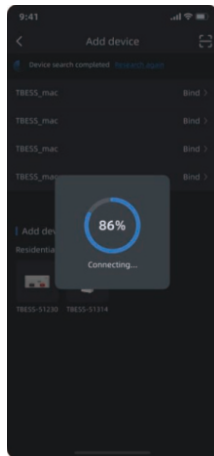

Figure 3

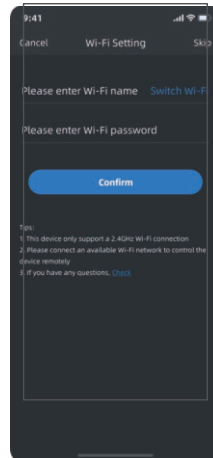

Figure 4

- 3) Figure 3: Bluetooth is **"Connecting"** and waiting for feedback on the connection result.
- 4) Figure 4: The Bluetooth **"Connection successful"** is displayed, and after 2 seconds, the **"WiFi settings"** page is entered.

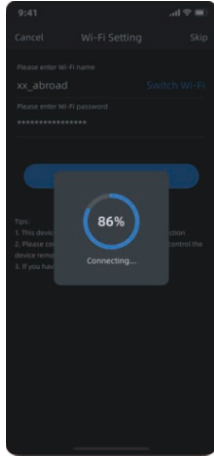

Figure 5



Figure 6

5) Figure 5: WiFi "**Connecting**", waiting for feedback on connection results; If the connection fails, you can try adding the device again based on the reason for the failure.

6) Figure 6: After successful WiFi setup, enter the "**Device Settings**" page to set personalized names for home storage.

### 3.2. Add device Manually

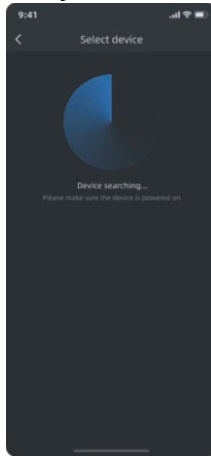

Figure 1

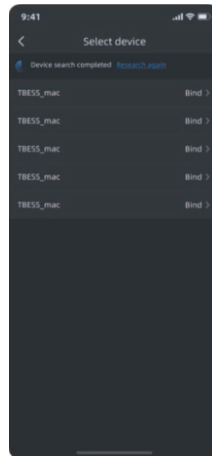

Figure 2

1) Figure 1: After selecting the device model, automatically search for the corresponding device.

2) Figure 2: Display the list of searched devices, select the device to be added, click "**Bind**" to start adding; If no device is found, you can click "**Research again**" or switch the addition method.

Figure 3

3) Figure 3: Bluetooth is "**Connecting**" and waiting for feedback on the connection result.

Note: Follow up steps can be found in "**Add device by Bluetooth Figures 4-6**".

## 14. Wireless module instructions(APP)

### 3.3. Abnormal condition

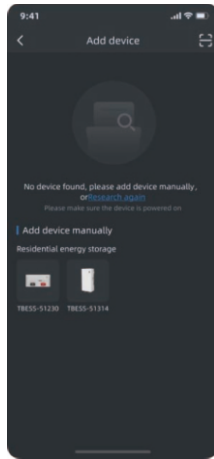

Figure 1

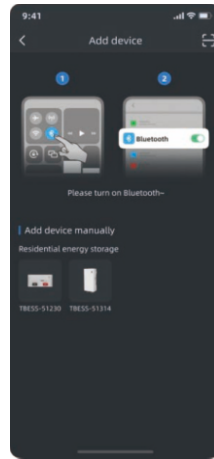

Figure 2

- 1) Figure 1: Confirm that the device has been turned on, try again near the device.
- 2) Figure 2: Please confirm that the Bluetooth on your phone is turned on.

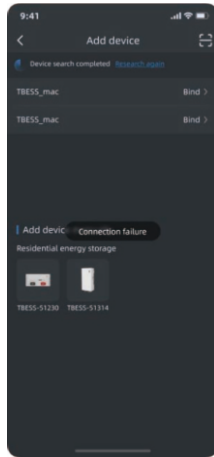

Figure 3

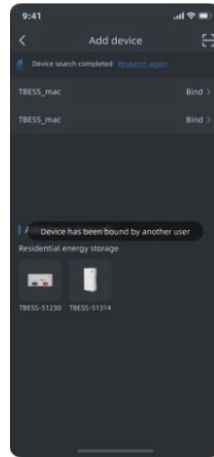

Figure 4

- 3) Figure 3: Add again after restarting the device.
- 4) Figure 4: The device has been bound. Please unbind it and add it again, or contact the device owner to share the device with you.

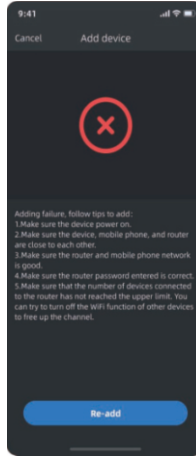

Figure 5

5) Figure 5: Refer to the prompt and add the device again.

## 4. Main functions

### 4.1. Main Information of Home Storage

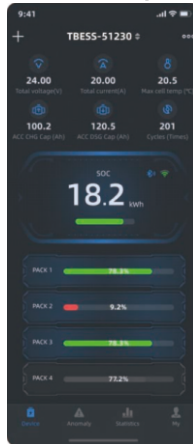

Figure 1

1) Figure 1: Display battery system information in sequence from top to bottom:

- Add: Click to jump to the device addition page
- Name: Display the name of the current home storage
- More: Click to enter the "More" page to view and set home storage information
- System data: Display real-time data, including total voltage, total current, maximum cell temperature, cumulative charge and discharge capacity, and number of cycles
- Home storage status: display system remaining battery, Bluetooth/WiFi connection status, fault status
- Battery pack status: displays the number, serial number, remaining power, charging and discharging status, and fault status of the battery pack

Reminder:

- Multi-battery parallel system can be viewed through the host.
- Drop down to refresh information; Online devices can view real-time data, while offline

## 14. Wireless module instructions(APP)

devices can view historical data.



Figure 2

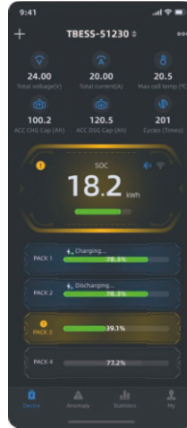

Figure 3

2 )Figure 2: Click on the top home storage name to expand the menu and display the list of bound devices. Click on any device name to quickly switch.

3 )Figure 3: When the device is abnormal, click on the abnormal information (blue alarm, yellow protection, red fault indicator) to jump to the "**Abnormal**" page to view details.

### 4.2. Home storage battery pack



Figure 1

1 )Figure 1: Display battery pack information in sequence from top to bottom:

- Battery pack: The current battery pack can be switched to other battery packs by clicking on it
- Battery pack status: display charging and discharging status, expected charging and discharging duration SOC、 Total voltage, total current SOH、 Cycle times, battery code, cumulative charge and discharge capacity
- Monitoring data: Display the highest/lowest cell voltage and serial number of the battery pack, the highest/lowest cell temperature, ambient temperature, and MOS temperature
- Cell voltage: displays the number of cell strings and corresponding cell voltage
- Alarm information: Display real-time and historical alarms information of the battery pack

## 5.2. Device Name

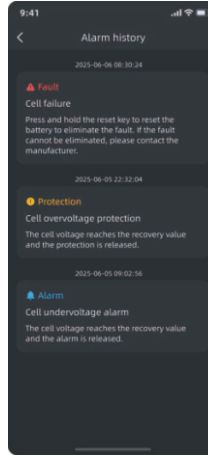

Figure 2

2) Figure 2: Click on "Alarm Information - Alarm history" to view the historical alarms of the battery pack.

## 5. More information

### 5.1. More information of device

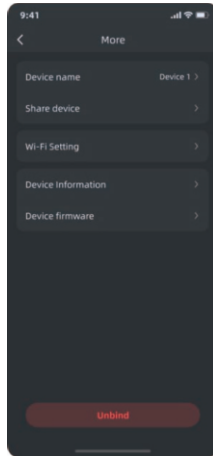

Figure 1

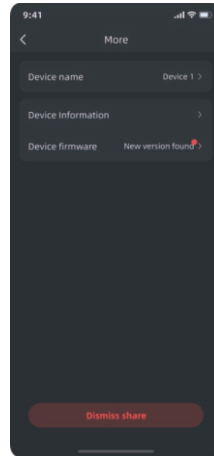
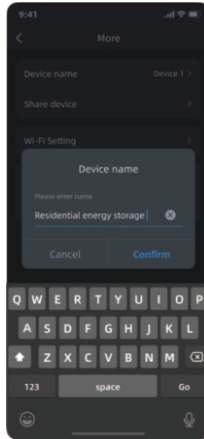

Figure 2

- 1) Figure 1: The device owner displays the following device information from top to bottom:
  - Device Name: Display home storage name, device owner can edit it
  - Sharing device: Manage shared users
  - WiFi setting: Configure WiFi for home storage connection
  - Device information: View home storage parameters
  - Device firmware: Check the system and DTU firmware versions, with a red dot indicating the new version
  - Unbind: Unbind the device from the account
- 2) Figure 2: The device sharing user only displays the device name, scheduled charging and discharging, device information, device firmware, and removal of sharing function.



Enter the device name that meets the requirements, click "**Confirm**" to complete the modification, and the name will be synchronized and updated to all device lists and shared user interfaces.

### 5.3. Share devices - via Account

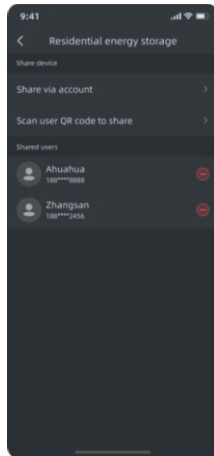

Figure 1

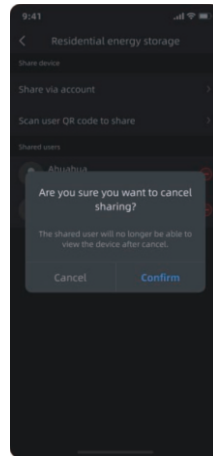

Figure 2

- 1) Figure 1: Supports sharing devices through accounts or QR codes; Display the shared users, click "**Delete**" to pop up a confirmation to cancel the sharing pop-up.
- 2) Figure 2: Click "**Confirm**" to remove the other party's sharing permission; Click '**Cancel**' to keep the sharing.

#### Tips:

- The device owner can modify the sharing permissions at any time
- After removing the sharing, the other party will immediately lose access permission
- All changes take effect in real-time

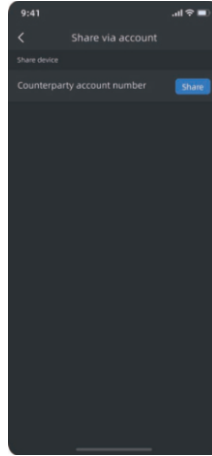

Figure 3

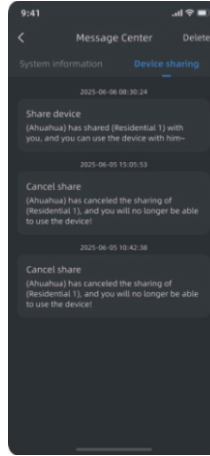

Figure 4

3 )Figure 3: Enter the other party's account to share;If it fails, you can share again according to the prompts.

4 )Figure 4: After entering the correct account to share, the other party can receive sharing messages in "My - Message Center - Device Sharing".

## 5.4. Share device - via QR code



Figure 1

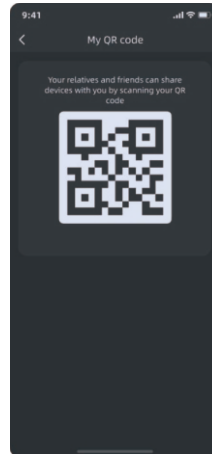

Figure 2

1 )Figure 1: Place the other party's QR code into the viewfinder, and after successful scanning, select the device to share;When the light is dim, click "**Turn on the flashlight**" to turn on the flashlight for auxiliary scanning.

2 )Figure 2: The other party can display the QR code of the sharing device in "My - My QR Code".

## 14. Wireless module instructions(APP)

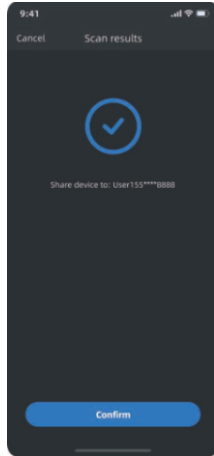

Figure 3

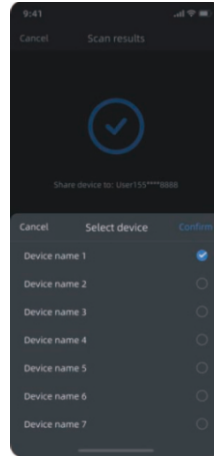

Figure 4

3) Figure 3: When there is only one device under your name, click **"Confirm"** to complete the sharing; If it fails, you can follow the prompts to share again.

4) Figure 4: When there are multiple devices under your name, you can select the device you want to share in the **"Select device"** pop-up window.

### 5.5. WiFi Settings

Before configuring WiFi, please ensure that the device is turned on and the Bluetooth of your phone is turned on. Only after the Bluetooth connection between your phone and the device is successful can you proceed with the configuration.

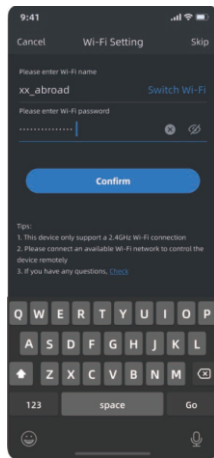

Figure 1

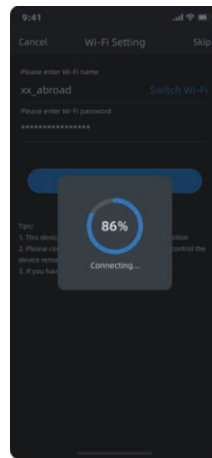

Figure 2

1) Figure 1: Display the **"WiFi Setting"** page.

2) Figure 2: WiFi **"Connecting"**, waiting for feedback on connection results; If the connection fails, you can try adding again based on the reason for the failure.

Note: If the setting fails, please refer to **"3 Important Tips"**.

## 5.6. Device Information

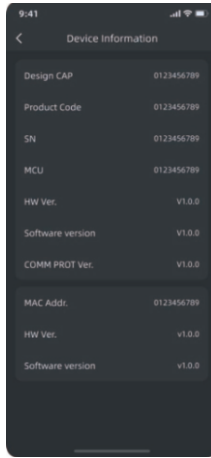

Display the design capacity, finished product code, SN, MCU and other information of the device.

## 5.7. Device Firmware version



Figure 1

1 )Figure 1: Check the current system firmware version and DTU firmware version of the device. When there is a new version, it will prompt "**New version found**" and can be upgraded.

## 14. Wireless module instructions(APP)

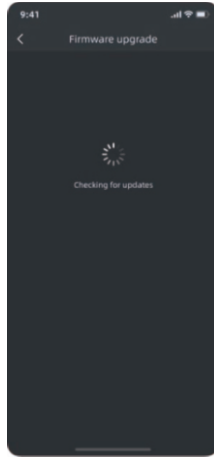

Figure 2

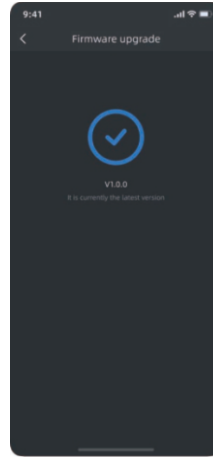

Figure 3

- 2)Figure 2: Check if there is a new firmware version available.  
3)Figure 3: It shows that the current version is already the latest.

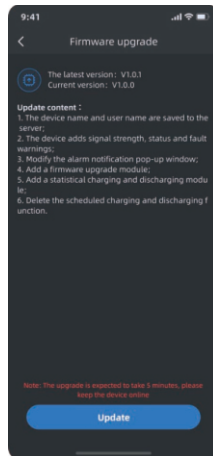

Figure 4

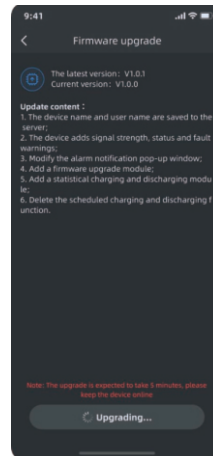

Figure 5

- 4)Figure 4: When a new firmware version is discovered, the update content will be displayed. Click "**Upgrade**" to start the upgrade process.  
5)Figure 5: Displaying upgrade in progress;Keep the device online during the upgrade process;Automatically exit the firmware upgrade page after success;Failed, please retry according to the prompt.

## 5.8. Unbind

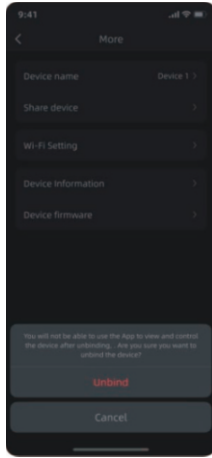

Figure 1

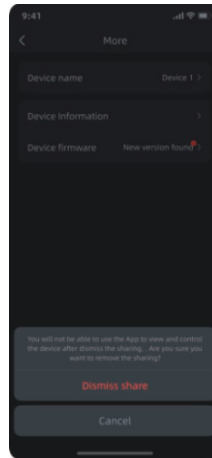

Figure 2

- 1) Figure 1: When the bound user clicks **"Unbind"** to unbind the device, the shared user will cancel the sharing and receives a notification.
- 2) Figure 2: The shared user clicks **"Dismiss share"** to remove the device, and the bound user receives a notification.

## 6. Anomaly

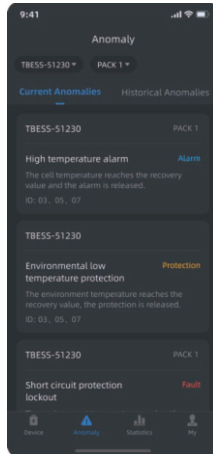

Figure 1

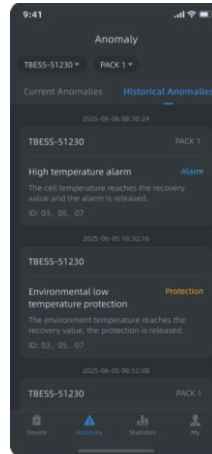

Figure 2

- 1) Figure 1: Display the current anomaly (alarm, protection, fault), showing the name of the home storage, battery pack number, anomaly title, level, and handling suggestions. It supports filtering by home storage name and battery pack number.
- 2) Figure 2: Display resolved historical anomalies in reverse chronological order, increasing the display of anomaly recovery time.

## 7. Statistics



Figure 1



Figure 2

- 1) Figure 1: The daily statistics page displays the statistical data of the selected device, including the clickable current date, the total amount of daily charging and discharging, as well as the line chart of daily charging and discharging.
- 2) Figure 2: The monthly statistics page displays the statistical data of the selected device, including the clickable total amount of current month, monthly charging and discharging, as well as a bar chart of daily charging and discharging.



Figure 3

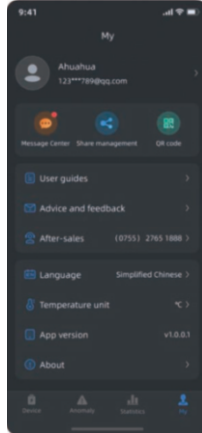

Figure 4

- 3) Figure 3: The annual statistics page displays the statistical data of the selected device, including the clickable total amount of current year, annual charging and discharging, as well as a bar chart of monthly charging and discharging.
- 4) Figure 4: The overall statistics page displays the total charging and discharging amounts of the selected devices, as well as a bar chart of the annual charging and discharging amounts.

## 14. Wireless module instructions(APP)

### 8. My 8.1. My



Display the following information from top to bottom:

- User Center: Display the user's profile picture, nickname, and account. Click on the profile picture to enter the personal center.
- Message Center: System messages and device sharing can be viewed
- Share Management: Manage "My Device" and "Share with Me" devices
- My QR code: Display personal QR code, user binds to shared device
- User guide: View product guide, WiFi distribution network common problems, etc
- Advice and Feedback: Submit feedback on product issues, app issues, and other issues
- After-sales: Display after-sales service hotline
- Language: Select language, supports Chinese and English
- Temperature unit: Select the temperature display unit, supporting °C and °F
- APP version: Display the current version number of the app
- About: Displaying User Agreement and Privacy Policy

### 8.2. User Center

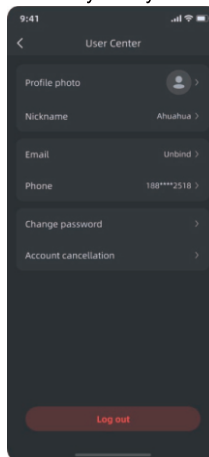

Figure 1

1 ) Figure 1: The following information is displayed in sequence from top to bottom:

- Profile photo: Supports taking photos or selecting images from albums as avatars
- Nickname: Customizable and modifiable nickname

## 14. Wireless module instructions(APP)

- Email/phone number: supports modifying registered email/phone number, or binding email/phone number for logging into the app
- Change password: Change login password through email or phone number
- Account cancellation: permanently delete the account and related data (non recoverable)
- Log out: Log out of the current login status

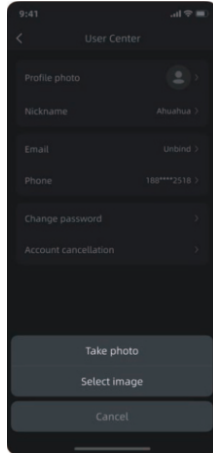

Figure 2

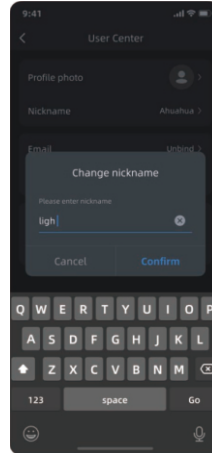

Figure 3

2 ) Figure 2: Select the replacement method, adjust the cropping area and save, and the avatar will be updated immediately.

3 ) Figure 3: Fill in the nickname in the input box and click "**Confirm**" to complete the modification.

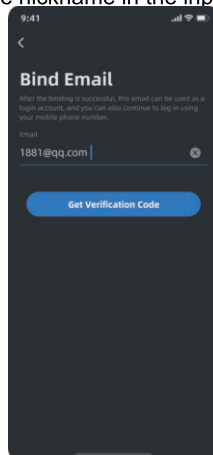

Figure 4

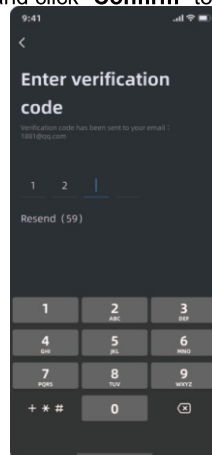

Figure 5

4 ) Figure 4: When the email/phone number is not bound, enter the email/phone number and click "**Get Verification Code**" to enter the verification code input page.

5 ) Figure 5: Enter the received verification code. If it is correct, the binding is successful. You can log in using your email/phone number next time.

## 14. Wireless module instructions(APP)

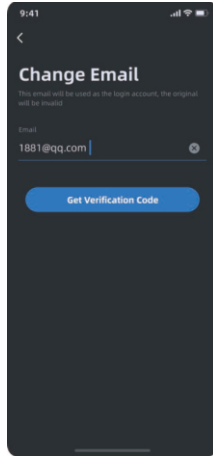

Figure 6

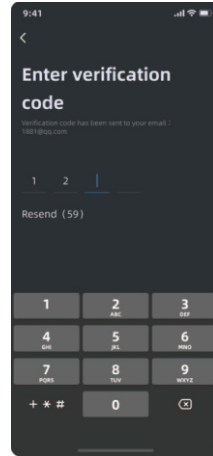

Figure 7

6 ) Figure 6: When modifying an email/phone number, enter the new email/phone number and click "**Get Verification Code**" to enter the verification code input page.

7 ) Figure 7: Enter the received verification code. If it is correct, the modification is successful. You can log in with a new email/phone number next time.

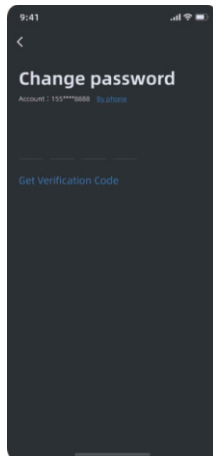

Figure 8

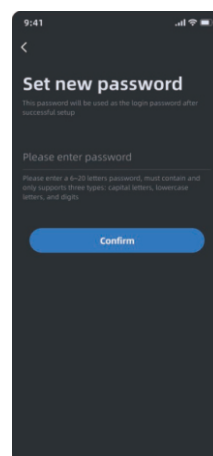

Figure 9

8 ) Figure 8: Already bound email/phone number, select the verification code acquisition method, enter the received verification code, and enter the password setting page.

9 ) Figure 9: Enter the new password that meets the requirements, click "**Confirm**" to complete the modification, and you can use the new password to log in next time.

## 14. Wireless module instructions(APP)

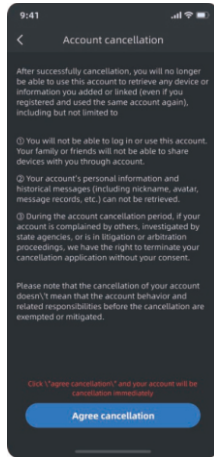

Figure 10

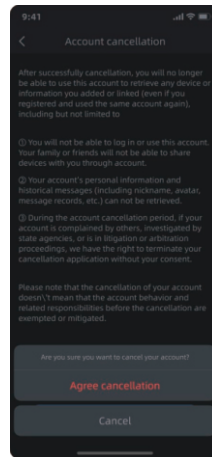

Figure 11

10 ) Figure 10: Display the prompt to cancel the account, click "**Agree cancellation**" to pop up a confirmation window for cancellation.

11 ) Figure 11: Click "**Agree cancelation!**" to cancel the account, return to the login page, and no longer be able to log in with this account;Click "**Cancel**" to keep the account.

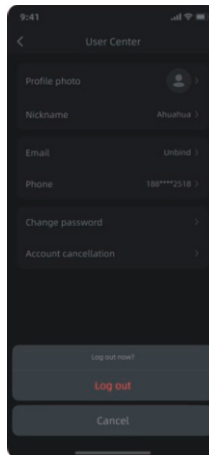

Figure 12

12 ) Figure 12: Click "**Log out**" to return to the login page;Click "**Cancel**" to keep the current login status.

# 14. Wireless module instructions(APP)

## 8.3. Message Center

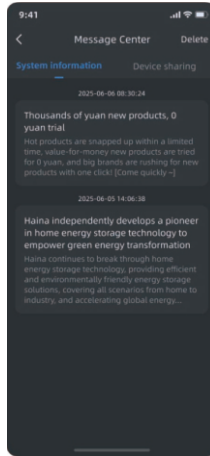

Figure 1

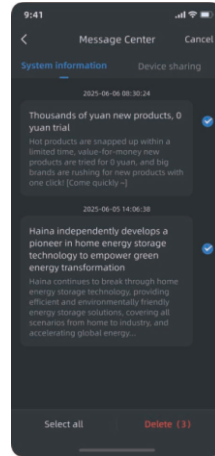

Figure 2

1 ) Figure 1: Display system or advertising messages, click to view message details.

2 ) Figure 2: Click on **"Delete"** in the upper right corner to select some or all messages for deletion.

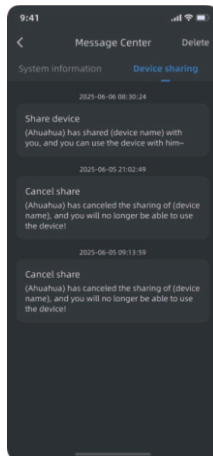

Figure 3

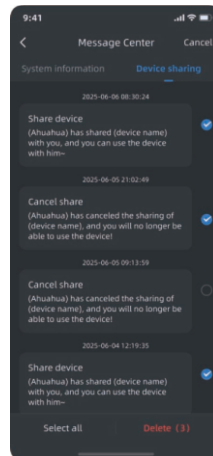

Figure 4

3 ) Figure 3: Display device sharing messages.

4 ) Figure 4: Click on **"Delete"** in the upper right corner to select some or all messages for deletion, but it will not affect the shared devices.

## 8.4. Share management

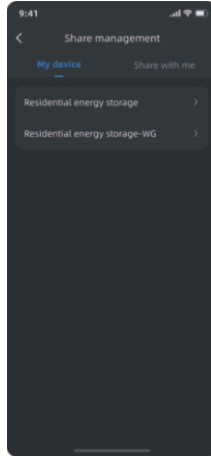

Figure 1

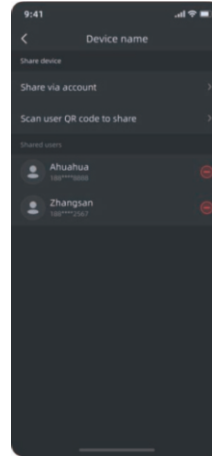

Figure 2

- 1 )Figure 1: Display the bound devices, select the device to enter the "Device Sharing" page.
  - 2 )Figure 2: Supports sharing devices through accounts or QR codes;Display shared users.
- Note: Follow up steps can be found in "5.3 Share devices - via Account" and "5.4 Share device - via QR Code" .

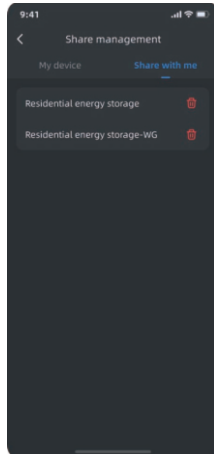

Figure 3

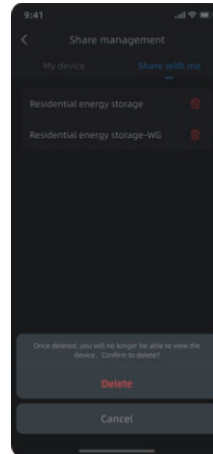
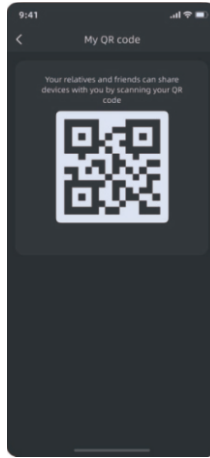

Figure 4

- 3 )Figure 3: Display the device shared with you, click "Delete" to pop up a confirmation of pop-up window to cancel the sharing.
- 4 )Figure 4: Click "Delete" to remove the sharing device;Click "Cancel" to keep the sharing.

## 8.5. My QR code



Display your QR code, your friends and family can scan it to share the device.

## 8.6. User guides

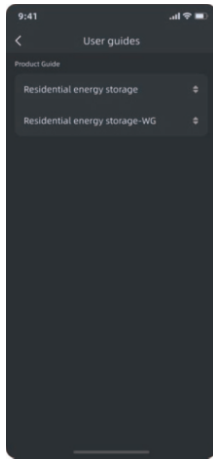

Figure 1

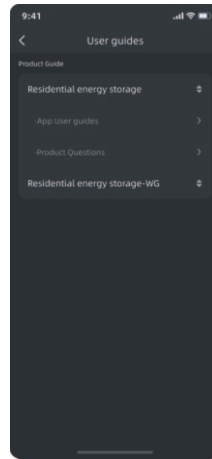
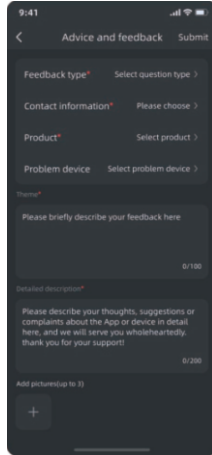

Figure 2

- 1 )Figure 1: Display a list of all supported product models.
- 2 )Figure 2: Click on the specific product model to view the corresponding user guide, problem description, and other documents.

Note : The document content may be updated, please refer to the actual content of the app.

## 8.7. Advice and feedback



You can provide feedback on the product, app, and other issues in the interface, and we will optimize and improve them as soon as possible. Your feedback is the driving force behind our progress!

## 8.8. After-sales

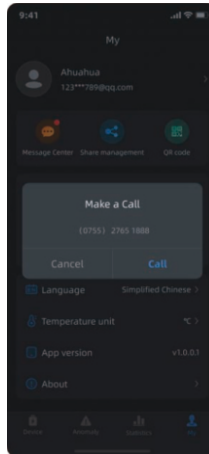

If you encounter any problems, please do not hesitate to call our after-sales hotline to contact us!

### 8.9. Language

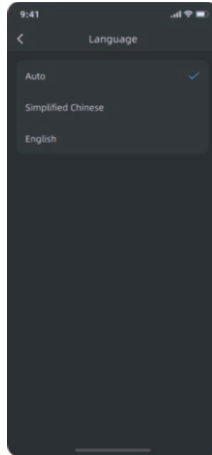

You can choose the language you want, currently supporting Chinese and English.

### 8.10. Temperature unit

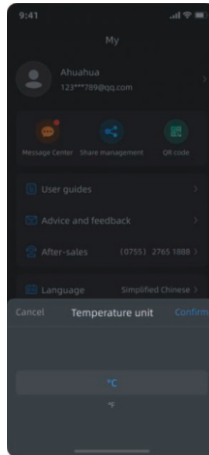

After selecting the temperature unit, click "**Confirm**" and the app will switch to the corresponding unit.

### 8.11. About

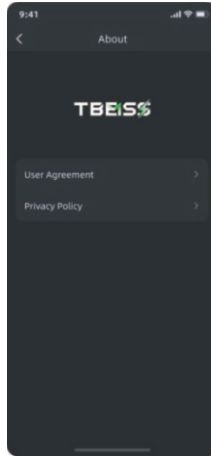

Display the name and protocol information of the app, click to view details.

Recommend charging method declared by the manufacturer :

Charge the battery at constant current 130A until voltage reaches 57.6V, then charge at constant voltage 57.6V till charge current is 14A

Manufacturer's Name: LEDXPRESS LIGHTING TECHNOLOGY CO.,LTD

Product name: Lithium Ion Batteries

Model : VT-14033

Working Temperature Range : 0-60°

This device was tested for operation s. To comply with RF exposure requirements, a minimum separation distance of 20 cm must be maintained between the user's body and the handset, including the antenna . Third-party belt-clips, holsters, and similar accessories used by this device should not contain any metallic components. Body-worn accessories that do not meet these requirements may not comply with RF exposure requirements and should be avoided . Use only the supplied or an approved antenna . This device in compliance with the essential requirements and other relevant provisions of Directive 2014/53/EU. All essential radio test suites have been carried out.

1. Use careful with the earphone maybe possible excessive sound pressure from earphones and headphones can



cause hearing loss.

2. CAUTION: RISK OF EXPLOSION IF BATTERY IS REPLACED BY AN INCORRECT TYPE. DISPOSE OF USED BATTERIES

ACCORDING TO THE INSTRUCTIONS

3. The product shall only be connected to a USB interface of version USB 2.0
4. Adapter shall be installed near the equipment and shall be easily accessible.
5. The plug considered as disconnect device of adapter
6. The device complies with RF specifications when the device used at 20 cm from your body
7. This product can be used across EU member states .



**V-TAC**  
Meaningful Innovation.

VTAC EUROPE LTD  
Bulgaria, Plovdiv 4000, bul.L.Karavelow 9B

